

Metal Seated Ball Valves
For Power & Industrial Applications



AGFT COMPANY

By Union Tech

Severe Service Ball Valves

Series Z1 Unibody Power Valve
Class 150-3500 & 4500 Sizes 1/2"- 4"

Series Z2 Two-Piece Industrial Valve
Class 150-2500 Sizes 1/2"- 24"

Series Z3 Three-Piece
Double Ball, Double Block & Bleed Valve



Their Options Are Our Standards

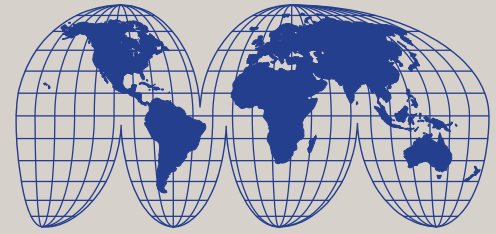

Manufacturer of Quality Valve Products Around the Globe

At Global Flow™ Technologies, formerly Zy-Tech, we are committed to improving our clients' operational and financial performance by supplying the most comprehensive range of valve products in the industry through our family of trusted valve brands.

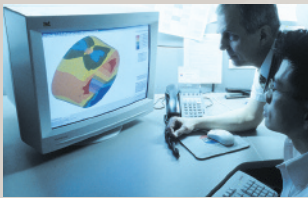

Engineering Expertise
GFT utilizes the latest state of the art engineering software to provide custom design services. Finite element analysis is one of many Design Verification

Tools GFT uses for designing valves to specific requirements.



Quality Control
All GFT Companies manufacture quality products that are designed and tested to meet the stringent standards of most Qualifying Authorities around the world. Advanced Engineering and our Quality Management System assure that our valve products continue to exceed your expectations.



Customer Service
GFT's Customer Service Departments are fully staffed with trained customer service representatives ready to help you with your order information, technical specifications and project logistics.



Manufacturing and Construction

All PBV® valves are manufactured of the highest quality materials with state-of-the-art CNC machines to assure critical

accuracy required for high performance zero-leakage metal seated ball valve construction. PBV® match laps all balls and seat surfaces for bubble tight sealing, plus all universal mounting brackets are machined to ISO standards.

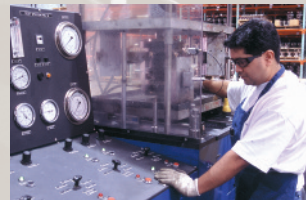

Compliance and Testing

All PBV® ball valves are manufactured and tested to comply with many international qualifying authorities as well as our own strict quality control procedures. Many procedures exceed

MSS-SP61, API-598 and ANSI FCI 70.2 Class VI.

All testing procedures comply with ANSI B16.34 and testing can be summarized as follows:

- Hydrostatic: 1.5 x max. CWP. Zero Leakage/60 seconds.
- High Press. Seat: 1.1 x max. CWP. Zero Leakage/60 seconds.
- Low Press. Seat: 50 psi. Zero Leakage/60 seconds.
- Additional, Air: 50 psi. Zero Leakage/60 seconds.

PBV® Severe Service Ball Valve Certification

Union Tech Company, Inc. meets or exceeds all requirements for ISO 9001:2000 certification and also implements their own stringent testing and quality assurance program requirements to meet the exacting standards of the industry's leading authorities and your specific application requirements. Contact your PBV® Union Tech representative for more information.

Visit us at www.globalflowtech.com
Toll Free: 1.800.231.3530

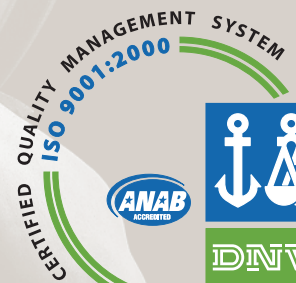

Introduction & How To Order 3
 Series Z1 Unibody Power Valve • Features, Applications, Dimensional Data, Parts & Materials 4-5
 Series Z2 Two-Piece Industrial Valve • Features, Applications, Dimensional Data, Parts & Materials 6-8
 Series Z3 Three-Piece Double Ball, Double Block & Bleed Valve • Features & Applications 9
 Series Z1 & Z2 Engineering Data • Flow Coefficient (C_v) & Nominal Pipe Size 10-11

PBV® Severe Service Ball Valve Solutions

PBV® Series Z1, Z2 & Z3 One, Two & Three-Piece Metal Seated Severe Service Ball Valves

PBV® introduces their NEW Series of Severe Service Ball Valves engineered for zero-leakage and critical applications.

When it comes to media leakage and critical isolation, now you can strike back with PBV®'s superior quality, long lasting, low maintenance metal seated ball valve solution.

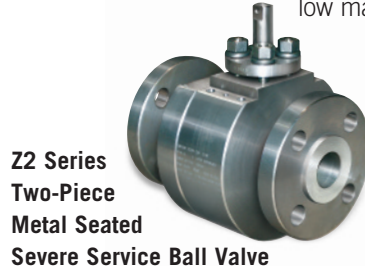

PBV® Severe Service Ball Valves • How To Order

Specifying PBV® Metal Seated Severe Service Valve Figure Numbers

Example: 2.5 x 2 Z125-2240C-99-G418 • This number represents a 2.5" NPS x 2" Bore Series Z1 One-Piece Power Valve in ANSI Class 2500, with F22 Body Material and 410 SS Ball and Seat Material Coated with HVOF Chromium Carbide, SWE Upstream End Connection and a SWE Downstream End Connection, equipped with Gear Operator and 4" Tall Mounting Bracket with an ISO F10 Mounting Pattern and a 36 mm Coupler.

2.5 x 2 Z1 25 - 22 40 C - 9 9 - G 4 1 8

Bore Size (in.)		Series	ANSI Class	Body Material	Ball & Seat Material	Ball & Seat Coating	Upstream End Conn.	Downstream End Conn.	Operator	Bracket Height	ISO 5211 Mounting Pattern	Coupler Size
Z1*	Z2**											
.65	1/2	Z1	10	5	36	C	1	1	A	4	0	6
1	3/4	1-PC Power Valve	150 Class	A105	316 SS	HVOF Chromium Carbide	Raised Face Flange	Raised Face Flange	Actuator	4"	F07	22 mm
1.4	1	Z1-SB	300 Class	F22	410 SS	Tungsten Carbide	3	3	Bare Stem (Specify)	6"	F10	27 mm
1.75	1 1/2	1-PC Sootblower	600 Class	F91	431 SS	HVOF Tungsten Carbide	RTJ	RTJ	Bracket & Mntg.Pad)	8"	F12	36 mm
2	2	Z2-FPU	900 Class	316 SS	431 SS	Tungsten Carbide	BWE (Specify Pipe Sched.)	BWE (Specify Pipe Sched.)	Gear	12"	F14	46 mm
2.5	3	2-PC Full Port	1500 Class	304 SS	F51 Duplex	Stellite®	8	8	Lever	16"	F16	Keyed
3	4	Z2-FPB	2500 Class	F51 Duplex	F55 Duplex	Special	NPT	NPT		Special	F25	Special
	6	2-PC Full Port	3200 Class	F55 Duplex	Monel®		SWE	SWE				
	8	Z2-RPU	3500 Class	Special	Hastelloy® C							
	10	2-PC Reduced Port Uni-direction.	4500 Class		Inconel® 718							
	12	Z2-RPB			Inconel® 625							
	14	2-PC Reduced Port Bi-directional			Special							
	16	Z3										
	18	3-PC Double Block & Bleed										

*When placing orders please include NPS x Bore size before "Series" number. **Z2 Valves are available in FP and RP configurations.

PBV® Z1 Unibody Power Valve • Features, Applications & Dimensional Data

PBV® Z1

One-Piece metal seated ball valves for high-pressure severe service applications including Power Generation and critical on/off applications.

- .65" - 3" Bore Size
- 1/2" - 4" Nominal Pipe Size
- 150-4500 ANSI Class
- 4 Year Warranty
- Design Meets ASME TDP-1 2006 Bore Requirements
- Material - A105, F22, F91 and 316 SS

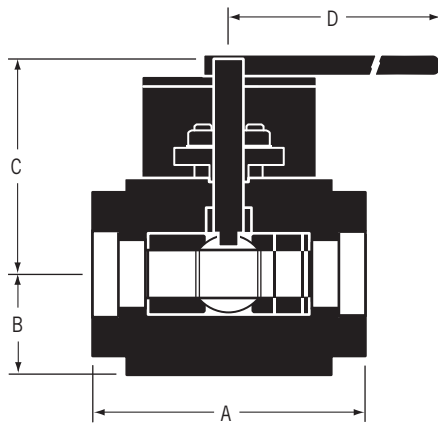
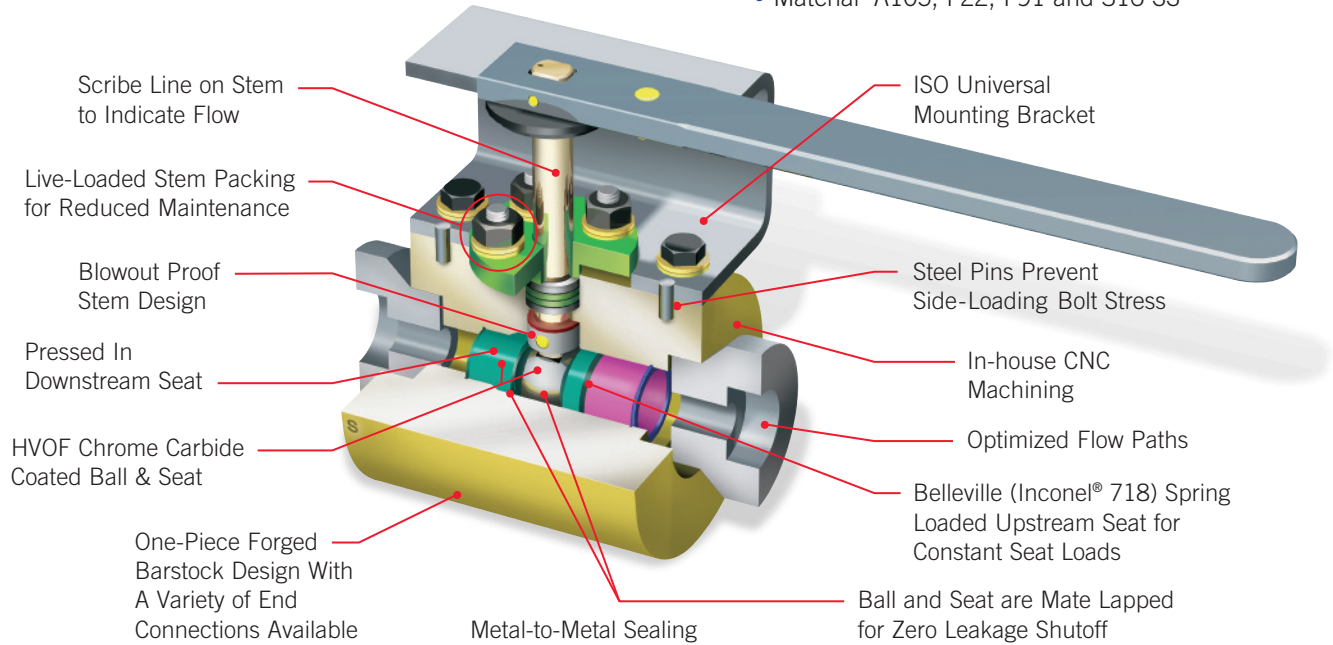

End Configuration Dimensions
NOTE: From Centerline of Valve.

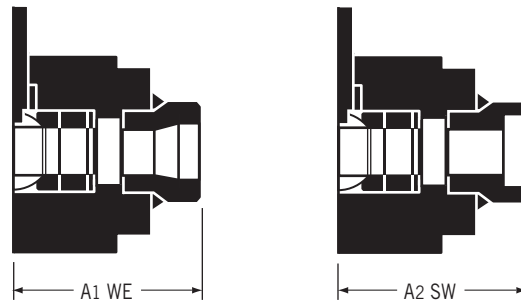

Dimensional Data

Bore Size (in.)*	A	A1 WE	A2 SW	B	C	D	Weight (lbs.)
.65	5.00	4.50	3.50	2.25	5.00	13.25	25
1.00	6.00	5.00	4.00	2.75	5.50	19.25	46
1.40	8.00	6.00	5.50	3.00	5.75	19.25	66
1.75	9.50	7.25	6.25	3.25	6.00	24.00	98
2.00	12.25	8.13	6.25	4.25	7.75	NA	170
2.50	14.00	**	9.50	5.50	10.50	NA	**
3.00	14.50	**	9.00	5.25	11.00	NA	**

* .65" & 1" Bore: 1" NPS SW & smaller use A2. 1.5" NPS SW & larger use A.

1.4" Bore: 1.5" NPS SW & smaller use A2. 2" NPS SW & 2.5" NPS SW use A.

1.75" Bore & larger, consult factory.

** Consult factory for dimensions and weights not listed.

Dependable Performance For All of Your Power Applications

PBV's Series Z1 Metal Seated Severe Service Ball Valve is designed for dependable zero leakage performance in high pressure, high temperature, clean critical steam applications.

Union Tech offers the Z1 Severe Service Ball Valve in a variety of sizes and materials to meet your specific application requirements. Contact your PBV® Union Tech Representative today for more information about PBV® Severe Service Ball Valves.

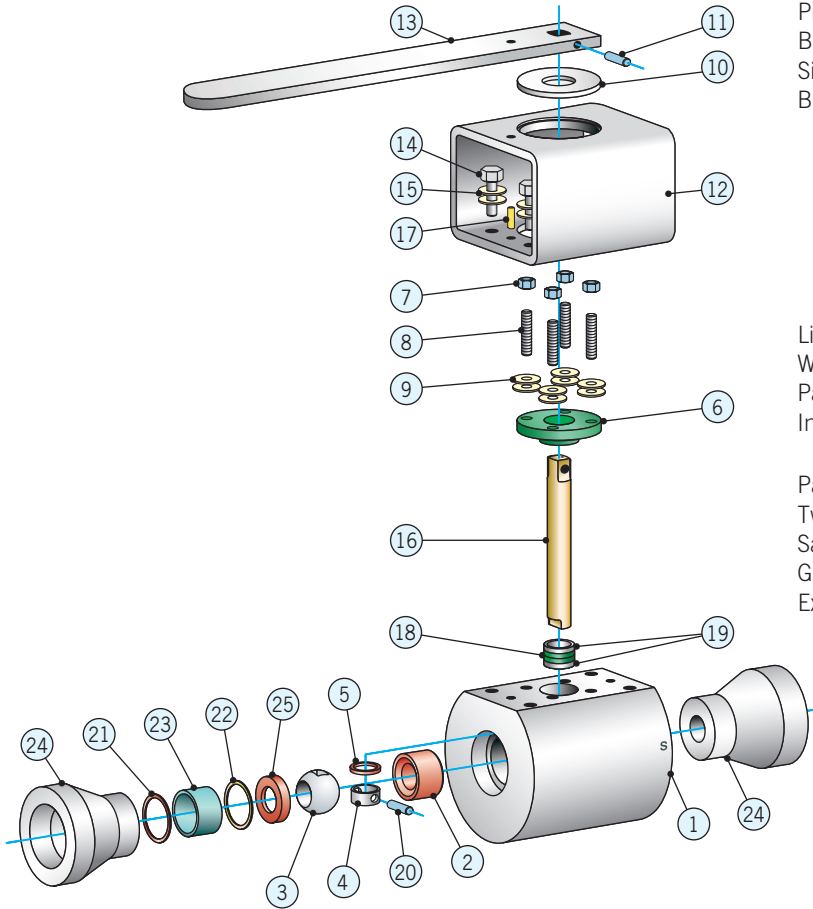

Pinned ISO Mounting Bracket Prevents Stem Side-Loading and Bolt Stress.

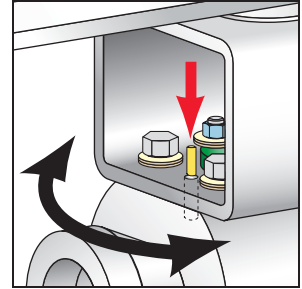

Live-Loading Belleville Washers Provide Constant Packing Pressure to Insure a Tight Seal.

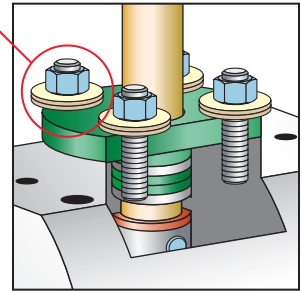

Packing Consists of Two GTP Graphite Rings Sandwiched Between Graphite Inconel® Anti-Extrusion Packing Rings.

4-Bolt Packing Gland Flange is Properly Spaced for Easy Access with Commercial Tools.

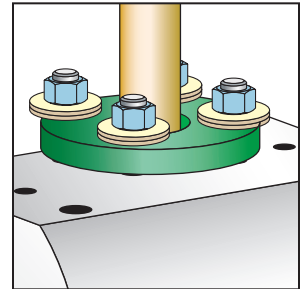

Parts & Materials

No.	Qty.	Description	Material			
			A105/LF2	A182 F22	A182 F91	A182 F316
1	1	Body	A105	A182 F22	A182 F91	A182 F316
2	1	Seal Seat	410SS/CCC	410SS/CCC	410SS/CCC	410SS/CCC
3	1	Ball	410SS/CCC	410SS/CCC	410SS/CCC	410SS/CCC
4	1	Stem Collar	410SS/QPQ	410SS/QPQ	410SS/QPQ	410SS/QPQ
5	1	Stem Bearing	410SS/QPQ	410SS/QPQ	410SS/QPQ	410SS/QPQ
6	1	Gland	410SS	410SS	410SS	410SS
7	1	Gland Nut	A193-B8M	A193-B8M	A193-B8M	A193-B8M
8	1	Gland Stud	A194-GR8	A194-GR8	A194-GR8	A194-GR8
9	1	Live-Loaded Spring	300SS	300SS	300SS	300SS
10	1	Adapter Bushing	Cast Iron	Cast Iron	Cast Iron	Cast Iron
11	1	Shear Pin	Carbon Steel	Carbon Steel	Carbon Steel	Carbon Steel
12	1	Mounting Bracket	CS ASTM A-500	CS ASTM A-500	CS ASTM A-500	CS ASTM A-500
13	1	Hand Lever	Carbon Steel	Carbon Steel	Carbon Steel	Carbon Steel
14	1	Hex Head Screw	J429 GR5	J429 GR5	J429 GR5	J429 GR5
15	1	Washer	Carbon Steel	Carbon Steel	Carbon Steel	Carbon Steel
16	1	Stem	A638 GR660	A638 GR660	A638 GR660	A638 GR660
17	1	Pin	Carbon Steel	Carbon Steel	Carbon Steel	Carbon Steel
18	1	Stem Packing	Grafoil®	Grafoil®	Grafoil®	Grafoil®
19	1	Stem Packing (Anti-Extrusion)	Grafoil®/Inconel®	Grafoil®/Inconel®	Grafoil®/Inconel®	Grafoil®/Inconel®
20	1	Load Pin	Inconel® 718	Inconel® 718	Inconel® 718	Inconel® 718
21	1	Retaining Ring	ASTM A286 GR660	ASTM A286 GR660	ASTM A286 GR660	ASTM A286 GR660
22	1	Spring	Inconel® 718	Inconel® 718	Inconel® 718	Inconel® 718
23	1	Transition Spacer	Carbon Steel	Carbon Steel	Carbon Steel	Carbon Steel
24	1	Socketweld Adapter	A105	A182 F22	A182 F91	A182 F316
25	1	Seat Pusher	410SS/QPQ	410SS/QPQ	410SS/QPQ	410SS/QPQ

NOTE: Trim is Inconel® 718 on Class 4500 valves.
We reserve the right to change materials and specifications.

PBV® Z2

Two-Piece metal seated ball valves for severe service applications including Chemical, Petro-Chemical, Abrasives, etc.

- 1/2" - 24" Nominal Pipe Size
- 150-2500 ANSI Class
- Standard and Full Port
- Available in SW, BW, FLF, RTJ, Hub and NPT Ends
- Materials: A-105, F-22, F-91, 316, Others Upon Request
- Uni or Bi-directional

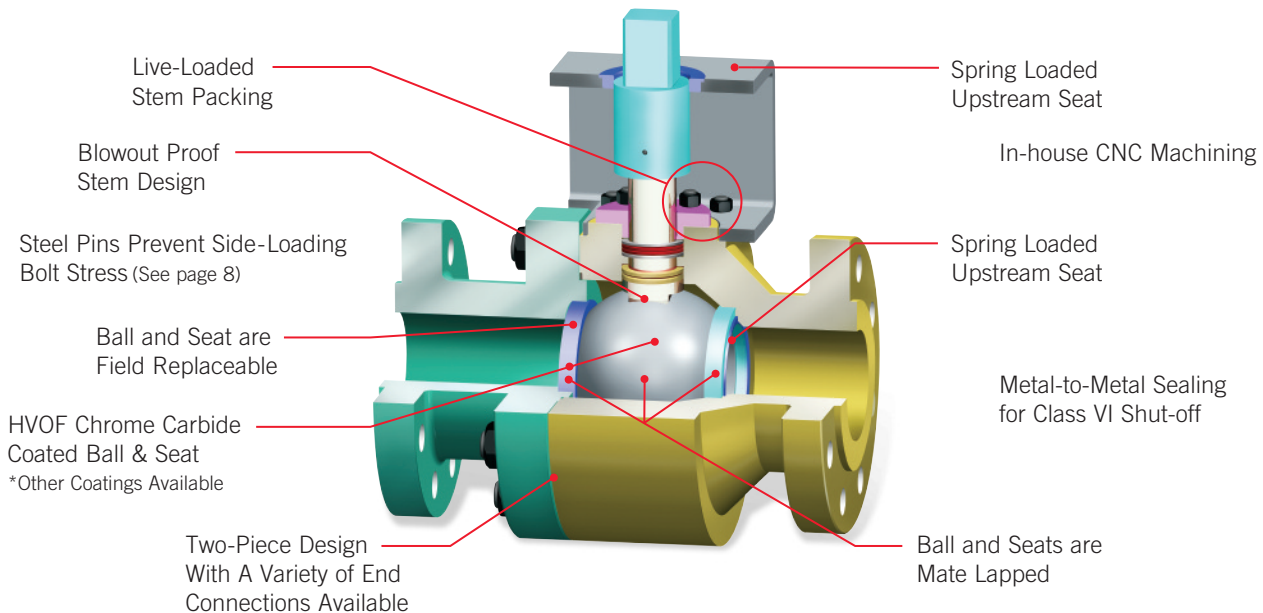

Rugged Design For All of Your Industrial Applications

PBV's Series Z2 Metal Seated Severe Service Ball Valve is designed for dependable performance in critical service industrial applications including Oil & Gas Refining, Petroleum & Petro Chemical production and many others.

Union Tech offers the Z2 Severe Service Ball Valve in a variety of sizes and materials to meet your specific application requirements. Contact your PBV® Union Tech Representative today for more information about PBV® Severe Service Ball Valves.

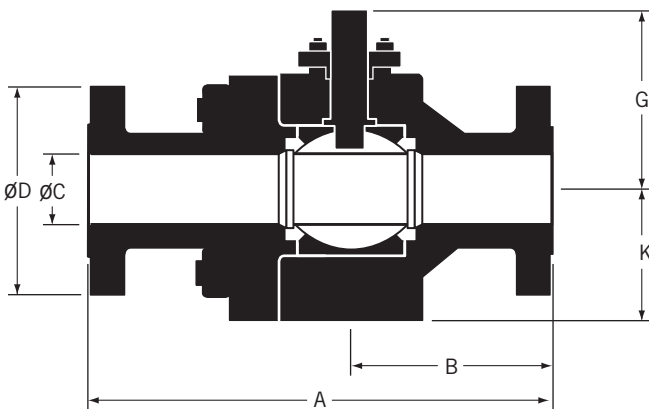

Class 150 Dimensional Data

Size (in.)	A	B	ØC	ØD	G	K
1/2	4.25	2.00	0.50	3.50	2.75	2.38
3/4	4.62	2.38	0.75	3.88	3.00	2.50
1	5.00	2.63	1.00	4.25	4.88	3.00
1 1/2	6.50	2.88	1.50	5.00	5.25	3.13
2	7.00	3.25	2.00	6.00	6.00	3.38
3	8.00	4.00	3.00	7.50	7.00	4.50
4	9.00	3.75	4.00	9.00	8.25	5.00
6	15.50	7.50	6.00	11.00	11.50	7.75
8	18.00	9.25	8.00	13.50	15.00	9.50
10	21.00	10.75	10.00	16.00	17.75	11.50
12	24.00	12.00	12.00	19.00	19.00	12.25
14	27.00	13.50	13.25	21.00	21.50	14.50
16	30.00	15.00	15.25	23.50	22.00	15.50
18	34.00	17.00	17.25	25.00	30.00	17.50
20	36.00	18.00	19.25	27.50	34.00	21.00
24	42.00	22.00	23.25	32.00	40.00	25.00

NOTE: Z2 Sizes are estimated.
Contact factory for verification when ordering.

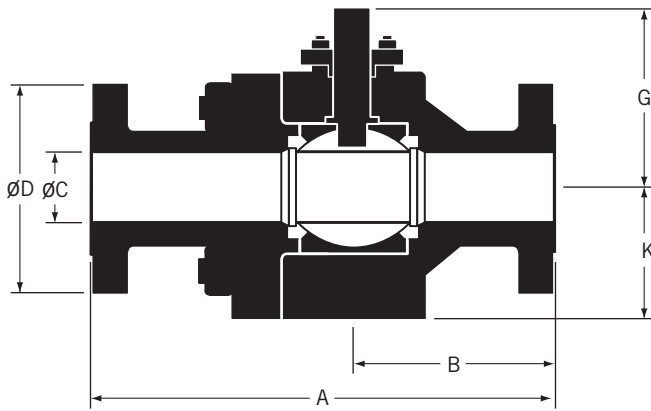

Class 300 Dimensional Data

Size (in.)	A	B	ØC	ØD	G	K
1/2	5.50	2.25	0.50	3.75	2.75	2.38
3/4	6.00	2.50	0.75	4.62	3.00	2.50
1	6.50	2.75	1.00	4.88	4.88	3.00
1 1/2	7.50	3.00	1.50	6.12	5.25	3.13
2	8.50	3.75	2.00	6.50	6.00	3.38
3	11.12	4.75	3.00	8.25	7.00	4.50
4	12.00	5.38	4.00	10.00	8.25	5.00
6	15.88	7.75	6.00	12.50	11.50	7.75
8	19.75	9.25	8.00	15.00	15.00	9.50
10	22.38	12.00	10.00	17.50	17.75	11.50
12	25.50	13.00	12.00	20.50	19.00	12.25
14	30.00	16.00	13.25	23.00	21.50	15.25
16	33.00	16.50	15.25	25.50	24.50	15.50
18	36.00	18.00	17.00	28.00	30.00	17.50
20	39.00	20.00	19.00	30.50	37.00	21.00
24	45.00	23.00	23.00	36.00	42.00	25.00

Class 600 Dimensional Data

Size (in.)	A	B	ØC	ØD	G	K
1/2	6.50	2.75	0.50	3.75	2.75	2.38
3/4	7.50	3.50	0.75	4.62	3.00	2.50
1	8.50	4.25	1.00	4.88	3.00	3.00
1 1/2	9.50	4.75	1.50	6.12	5.25	3.50
2	11.50	5.00	2.00	6.50	6.00	3.75
3	14.00	6.00	3.00	8.25	7.00	4.75
4	17.00	7.75	4.00	10.75	8.25	5.00
6	22.00	9.00	6.00	14.00	11.50	8.00
8	26.00	12.25	7.87	16.50	15.88	10.25
10	31.00	14.00	9.75	20.00	18.00	11.50
12	33.00	16.00	11.75	22.00	20.00	12.25
14	35.00	17.50	12.87	23.75	24.00	16.00
16	39.00	20.25	14.75	27.00	26.00	16.00
18	43.00	22.50	16.50	29.25	32.00	18.00
20	47.00	23.75	18.25	32.00	38.00	21.00
24	55.00	28.00	22.00	37.00	44.00	25.00

Class 900 Dimensional Data

Size (in.)	A	B	ØC	ØD	G	K
1/2	9.00	4.50	0.50	4.75	2.75	3.00
3/4	9.00	4.50	0.69	5.12	3.00	3.00
1	10.00	5.00	0.87	5.88	4.88	3.00
1 1/2	12.00	6.00	1.37	7.00	5.25	4.31
2	14.50	6.50	1.87	8.50	6.00	4.50
3	15.00	7.00	2.87	9.50	7.00	5.00
4	18.00	7.50	3.87	11.50	8.25	6.75
6	24.00	9.50	5.75	15.00	11.50	9.00
8	29.00	14.00	7.50	18.50	15.00	11.50
10	33.00	16.00	9.37	21.50	17.75	13.75
12	38.00	18.00	11.12	24.00	19.00	15.50

Class 1500 Dimensional Data

Size (in.)	A	B	ØC	ØD	G	K
1/2	9.00	4.50	0.50	4.75	4.75	3.00
3/4	9.00	4.50	0.69	5.12	4.75	3.00
1	10.00	5.00	0.87	5.88	4.75	3.00
1 1/2	12.00	6.00	1.37	7.00	7.50	3.50
2	14.50	6.50	1.87	8.50	8.25	4.38
3	18.50	8.50	2.75	10.50	9.50	5.50
4	21.50	9.75	3.62	12.25	12.13	7.25
6	27.75	11.00	5.37	15.50	17.50	10.00
8	32.75	14.00	7.00	19.00	20.00	12.50
10	39.00	16.00	8.75	23.00	21.00	15.50
12	44.50	19.00	10.37	26.50	24.00	14.00

Class 2500 Dimensional Data

Size (in.)	A	B	ØC	ØD	G	K
1/2	9.00	4.50	0.44	5.25	4.75	3.00
3/4	9.00	4.50	0.56	5.50	4.75	3.00
1	10.00	5.00	0.75	6.25	4.75	3.00
1 1/2	12.00	6.00	1.12	8.00	7.00	4.50
2	17.75	7.25	1.50	9.25	9.00	6.00
3	22.75	10.00	2.25	12.00	11.75	8.50
4	26.50	11.00	2.87	14.00	13.25	7.50
6	36.00	13.00	4.37	19.00	15.00	11.00
8	40.25	14.50	5.75	21.75	24.00	13.00
10	50.00	19.00	7.25	26.50	26.00	13.50
12	56.00	22.00	8.62	30.00	28.00	18.50

NOTE: Z2 Sizes are estimated. Contact factory for verification when ordering. Sizes 14"-24" are available upon request.

PBV® Z2 Two-Piece Industrial Valve • Parts & Materials

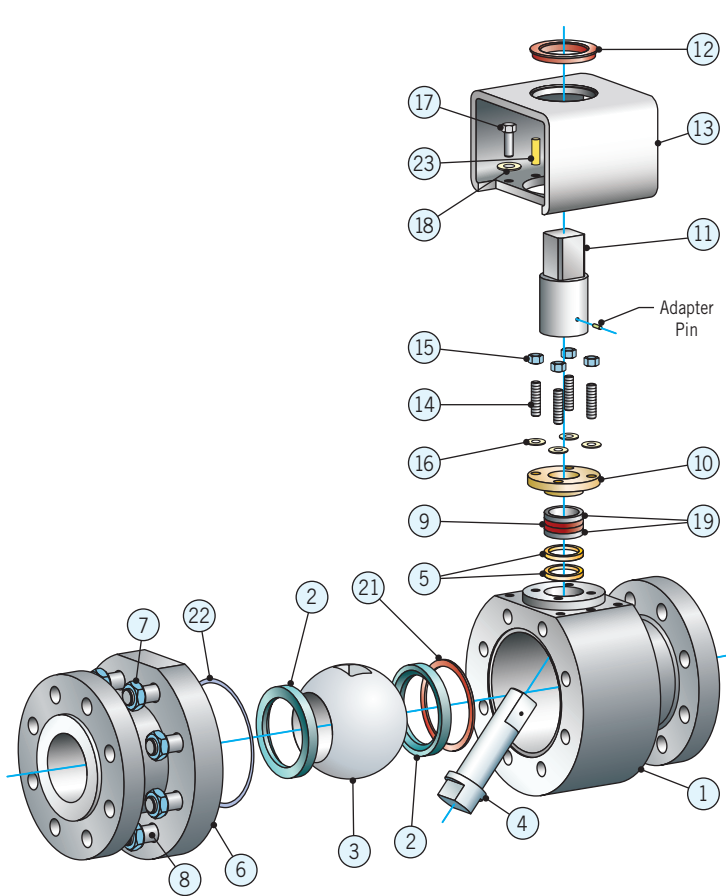

Pinned ISO Mounting Bracket Prevents Stem Side-Loading and Bolt Stress.

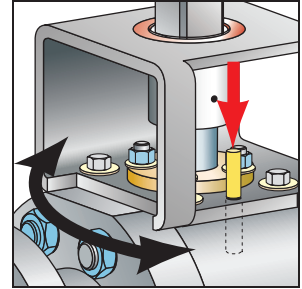

Packing Consists of Two GTP Graphite Rings Sandwiched Between Graphite Inconel® Anti-Extrusion Packing Rings.

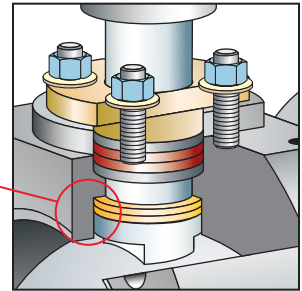

Coated Stem Bearing to Reduce Stem Torque

Parts & Materials

No.	Qty.	Description	Material			
			A105/LF2	A182 F22	A182 F91	A182 F316
1	1	Body	A105	A182 F22	A182 F91	A182 F316
2	2	Seal Seat	410SS/CCC	410SS/CCC	410SS/CCC	410SS/CCC
3	1	Ball	410SS/CCC	410SS/CCC	410SS/CCC	410SS/CCC
4	1	Stem	A638 GR660	A638 GR660	A638 GR660	A638 GR660
5	1	Stem Bearing	410SS/QPQ	410SS/QPQ	410SS/QPQ	410SS/QPQ
6	1	End Connection	A105	A105	A105	A105
7	1	Body Nut	ASTM A194-GR2H	ASTM A194-GR4H	ASTM A194-GR4H	ASTM A194-GR8
8	1	Body Stud	ASTM A193-B7	ASTM A193-B16	ASTM A193-B16	ASTM A193-B8
9	1	Stem Packing	Grafoil®	Grafoil®	Grafoil®	Grafoil®
10	1	Gland Flange	410SS	410SS	410SS	410SS
11	1	Stem Adapter	4140HT	4140HT	4140HT	4140HT
12	1	Adapter Bushing	Cast Iron	Cast Iron	Cast Iron	Cast Iron
13	1	Mounting Bracket	CS ASTM A-500	CS ASTM A-500	CS ASTM A-500	CS ASTM A-500
14	1	Gland Stud	A193-B8M	A193-B8M	A193-B8M	A193-B8M
15	1	Gland Nut	A194-GR8	A194-GR8	A194-GR8	A194-GR8
16	1	Gland Lock Washer	300SS	300SS	300SS	300SS
17	1	Bracket Bolts	A574 GR5	A574 GR5	A574 GR5	A574 GR5
18	1	Bracket Lock Washer	Carbon Steel	Carbon Steel	Carbon Steel	Carbon Steel
19	1	Stem Packing (Anti-Extrusion)	Grafoil®	Grafoil®	Grafoil®	Grafoil®
21	1	Spring	Inconel® 718	Inconel® 718	Inconel® 718	Inconel® 718
22	1	Body Gasket	316/Grafoil® Filled	316/Grafoil® Filled	316/Grafoil® Filled	316/Grafoil® Filled
23	2	Mounting Bracket Pin	Carbon Steel	Carbon Steel	Carbon Steel	Carbon Steel

NOTE: We reserve the right to change materials and specifications.

PBV® Z3

Three-Piece metal seated double block and bleed ball valves for severe service applications.

- .65"-3" Bore Size
- 1/2" - 4" Nominal Pipe Size
- 150-1500 ANSI Class
- Available in SW, BW, FLG and NPT Ends
- Materials: A-105, F-22, F-91, 316 and others upon request

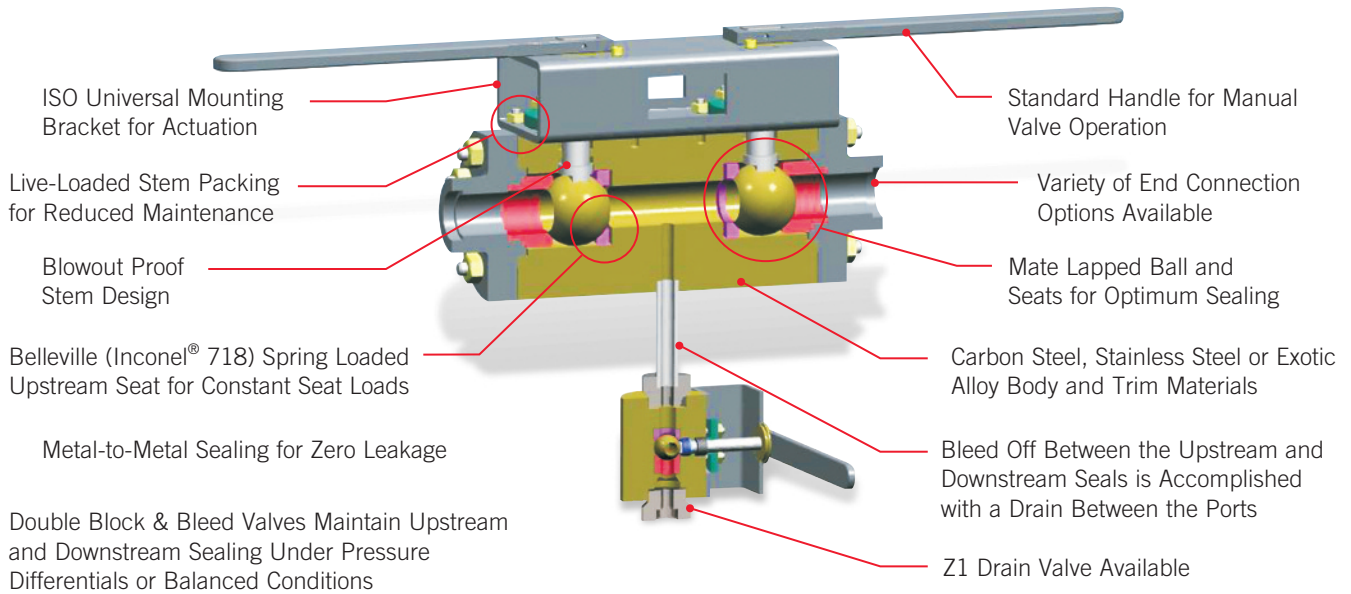

Rugged Design For All of Your Industrial Applications

PBV®'s Series Z3 Double Block & Bleed Metal Seated Severe Service Ball Valve is designed for dependable performance including Clean Critical Service, Oil & Gas Refining, Petroleum & Petro Chemical Production and many others. With two isolation points for zero leakage, the Z3 is designed to maintain upstream and downstream sealing under pressure differentials or balanced conditions.

Union Tech offers the Z3 Double Block & Bleed Metal Seated Severe Service Ball Valve in a variety of sizes and materials to meet your specific application requirements. Contact your PBV® Union Tech Representative today for more information about Series Z3 Ball Valves.

The Cv for valves indicates the flow capacity of the valve. Cv by definition is the volume of water in gallons per minute at 60° F that will flow through a given element with a pressure drop of 1 psig.

Series Z1 • Flow Coefficients (Cv)

Valve Size (in.)	Bore Size (in.)/Pipe Schedule													
	.65		1.00		1.40		1.75		2.00		2.50		3.05	
	80	160	80	160	80	160	80	160	80	160	80	160	80	160
1/2	22	22	—	—	—	—	—	—	—	—	—	—	—	—
3/4	32	40	—	—	—	—	—	—	—	—	—	—	—	—
1	31	26	103	74	—	—	—	—	—	—	—	—	—	—
1 1/2	15	16	48	56	155	212	—	—	—	—	—	—	—	—
2	14	15	40	46	105	135	264	375	466	347	—	—	—	—
2 1/2	—	—	36	37	86	94	170	208	304	400	—	—	—	—
3	—	—	28	29	75	80	135	150	202	234	481	655	—	—
4	—	—	—	—	56	58	115	120	160	172	296	342	588	785

NOTE: For other pipe sizes not in the chart, contact factory.

Series Z2 • Flow Coefficients (Cv)

Valve Size (in.)	Flow Coefficients (Cv) Rating					
	Class 150	Class 300	Class 600	Class 900	Class 1500	Class 2500
1/2	26	26	26	26	26	20
3/4	62	62	62	52	52	33
1 x 1 1/2	8	8	8	9	9	10
1	114	114	114	84	84	61
1 1/2 x 1	40	40	40	45	45	70
1 1/2	270	270	270	223	223	145
2 x 1 1/2	105	105	105	120	120	270
2	500	500	500	432	432	270
3 x 2	159	159	159	168	177	286
3	1175	1175	1175	1070	978	640
4 x 3	427	427	427	454	528	640
4	2160	2160	2160	2013	1748	1070
6 x 4	787	787	787	830	916	1515
6	5076	5076	5076	4641	4018	2602
8 x 6	1724	1724	2161	2376	2815	—
8	9300	9300	8985	8120	7022	4641
10 x 8	4250	4250	4502	4992	6246	6622
10	14,865	14,865	14,095	12,966	11,228	7560
12 x 10	7348	7348	7776	9268	12,411	—
12	21,799	21,799	20,857	18,578	16,044	10,880
14 x 12	13,793	13,793	15,502	19,581	—	—
16 x 14	19,916	19,916	23,040	30,125	—	—
18 x 16	23,588	25,508	30,887	39,857	—	—
20 x 18	36,010	38,269	47,203	—	—	—
24 x 20	32,665	33,972	39,620	48,573	—	—

NOTE: I.D. of valve size is based on ASME B16.34 Annex A. Please contact factory for additional valve sizes.

Relationship Between Nominal Pipe Size and Inside Diameter

The Table below is based on the dimensions given in B16.34 dimensional tables as “Inside Diameter of Fitting.”

The valves above nominal pipe size 24" for the lower pressure classes and above nominal pipe size 12" for Class 2500 are obtained by linear extrapolation.

Nominal Pipe Size (in.)	Inside Diameter (in.)						
	Class 150	Class 300	Class 400	Class 600	Class 900	Class 1500	Class 2500
1/2	0.50	0.50	0.50	0.50	0.50	0.50	0.44
3/4	0.75	0.75	0.75	0.75	0.69	0.69	0.56
1	1.00	1.00	1.00	1.00	0.87	0.87	0.75
1 1/4	1.25	1.25	1.25	1.25	1.12	1.12	1.00
1 1/2	1.50	1.50	1.50	1.50	1.37	1.37	1.12
2	2.00	2.00	2.00	2.00	1.87	1.87	1.50
2 1/2	2.50	2.50	2.50	2.50	2.25	2.25	1.87
3	3.00	3.00	3.00	3.00	2.87	2.75	2.25
4	4.00	4.00	4.00	4.00	3.87	3.62	2.87
5	5.00	5.00	5.00	5.00	4.75	4.37	3.62
6	6.00	6.00	6.00	6.00	5.75	5.37	4.37
8	8.00	8.00	8.00	7.87	7.50	7.00	5.75
10	10.00	10.00	10.00	9.75	9.37	8.75	7.25
12	12.00	12.00	12.00	11.75	11.12	10.37	8.62
14	13.25	13.25	13.12	12.87	12.25	11.37	9.50
16	15.25	15.25	15.00	14.75	14.00	13.00	10.87
18	17.25	17.00	17.00	16.50	15.75	14.62	12.25
20	19.25	19.00	18.87	18.25	17.50	16.37	13.50
22	21.25	21.00	20.75	20.12	19.25	18.00	14.87
24	23.25	23.00	22.62	22.00	21.00	19.62	16.25

NOTE: The information above is a nonmandatory part of ASME B16.34-1996 and is provided for informational purposes only. The information above is calculated for flanged end connections.

Pipe Schedule & Wall Thickness Chart

Formula: $NOD - (2 \times WT) = ID$

Nominal Pipe Size (in.)	OD (in.)	Pipe Schedule / Wall Thickness (in.)															
		5s	5	10s	10	20	30	40s & Std.	40	60	80s & E.H.	80	100	120	140	160	Double E.H.
1/2	.840	.065	.065	.083	.083			.109	.109		.147	.147				.187	.294
3/4	1.050	.065	.065	.083	.083			.113	.113		.154	.154				.218	.308
1	1.315	.065	.065	.109	.109			.133	.133		.179	.179				.250	.358
1 1/4	1.660	.065	.065	.109	.109			.140	.140		.191	.191				.250	.382
1 1/2	1.900	.065	.065	.109	.109			.145	.145		.200	.200				.281	.400
2	2.375	.065	.065	.109	.109			.154	.154		.218	.218				.343	.436
2 1/2	2.875	.083	.083	.120	.120			.203	.203		.276	.276				.375	.552
3	3.500	.083	.083	.120	.120			.216	.216		.300	.300				.437	.600
3 1/2	4.000	.083	.083	.120	.120			.226	.226		.318	.318					.636
4	4.500	.083	.083	.120	.120			.237	.237	.281	.337	.337		.437		.531	.674
4 1/2	5.000							.247			.355						.710
5	5.563	.109	.109	.134	.134			.258	.258		.375	.375		.500		.625	.750
6	6.625	.109	.109	.134	.134			.280	.280		.432	.432		.562		.718	.864
7	7.625							.301			.500						.875
8	8.625	.109	.109	.148	.148	.250	.277	.322	.322	.406	.500	.500	.593	.718	.812	.906	.875
9	9.625							.342			.500						
10	10.750	.134	.134	.165	.165	.250	.307	.365	.365	.500	.500	.593	.718	.843	1.000	1.125	
11	11.750							.375			.500						
12	12.750	.156	.165	.180	.180	.250	.330	.375	.406	.562	.500	.687	.843	1.000	1.125	1.312	
14	14.000	.156		.188	.250	.312	.375	.375	.437	.593	.500	.750	.937	1.093	1.250	1.406	
16	16.000	.165		.188	.250	.312	.375	.375	.500	.656	.500	.843	1.031	1.218	1.437	1.593	
18	18.000	.165		.188	.250	.312	.437	.375	.562	.750	.500	.937	1.156	1.375	1.562	1.781	
20	20.000	.188		.218	.250	.375	.500	.375	.593	.812	.500	1.031	1.280	1.500	1.750	1.968	
24	24.000	.218		.250	.250	.375	.562	.375	.687	.968	.500	1.218	1.531	1.812	2.062	2.343	

PBV General Terms and Conditions of Sale

By acceptance of the goods described herein, the Purchaser expressly acknowledges and agrees to the following general terms and conditions of sale (the "Terms and Conditions"):

- 1. Warranty:** The warranty described below applies only to new or unused goods or goods reconditioned by PBV® Valve (Seller). The Seller specifically disclaims any warranty for used goods or goods sold as is. For a period of one (1) year after date of shipment of any of the goods described herein, Seller warrants such goods shall remain free from failure due to defects in workmanship and materials incorporated therein by or for Seller provided such failure shall not have been caused or contributed to by improper usage, storage, service application, installation or maintenance, repairs, alterations, or modifications effected by or for the user; or misuse, negligence or accident. In the event of failure for which Seller has assumed warranty obligations hereunder, and provided Purchaser provides written notification of such failure immediately to Seller, Seller agrees to repair, or at its option, to replace the goods sold at its sole expense. Apart from the warranty and undertaking above set forth, or unless otherwise specifically consented to in writing by Seller, Seller assumes no obligation or liability for losses, expenses or damages, direct or consequential, suffered or incurred as a result of any failure of, or defect in, the goods described herein, including but not limited to, such losses, expenses or damages as may result from the necessity to remove, replace, restore or transport the goods from any location or service in which they may be used, regardless of the cause of such failure or defect. This warranty extends only to the original Purchaser of the goods and is the only warranty made by Seller in connection herewith; provided, however, that if such original purchaser is a reseller or distributor of Seller's goods, such warranty shall also extend to any person or entity that purchases such goods directly from such reseller or distributor. There are no other warranties, express or implied, of any kind given with respect to the goods, their merchantability, fitness for any particular purpose or usage, or otherwise, nor is any person authorized to extend on behalf of Seller any form of warranty other than that above set forth. The goods described herein are not sold or distributed by Seller for personal, family or household purposes, nor are they normally suited for use as such.
- 2. Prices:** Prices and other terms of sale where set forth in current price sheets are subject to change without notice. Stenographic or clerical errors are subject to correction.
- 3. Acceptance of Orders and Assignment:** All orders are subject to acceptance by Seller at its home office, Stafford, Texas, only. No assignment of the Purchaser's rights or obligations under any purchase order may be made without the prior written consent of the Seller.
- 4. Terms, Payment and Partial Shipment:** All accounts are payable net 30 days from invoice date. Seller shall charge one percent (1%) per month interest charged on accounts after 30 days from invoice date, or twelve percent (12%) annually. All accounts are payable in United States dollars, free of exchange, collection, or any other charges. If in the sole discretion of Seller, the financial condition of the Purchaser at any time so requires, Seller retains the right to require full or partial payment in advance, to set spending limits for credit accounts or to require other adequate assurances of financial responsibility. Seller reserves the right to make partial shipments from time to time and render invoices therefore, which shall be due and payable as provided in said invoices.
- 5. Freight Charges:** Unless otherwise specifically noted, standard shipping charges (calculated by product weight, not including packaging) shall be added or be in addition to the price quoted and Purchaser agrees to pay the same to Seller.
- 6. Taxes:** Unless otherwise specifically noted, the amount of any sales, use, value added, occupancy, excise tax, or other tax, of any nature, federal, state, or local, for which Seller is legally liable, either initially or through failure of payment by Purchaser, shall be added or be in addition to the price quoted and Purchaser agrees to pay the same to Seller.
- 7. Unavoidable Conditions:** Seller shall not be liable for failure to deliver or delays in delivery occasioned by causes beyond its control, including, without limitation, strikes, lockouts, fires, embargoes, war or other outbreaks of hostilities, acts of God, inability to obtain shipping space, machinery, breakdowns, delays of carriers or suppliers, and governmental acts or regulations.
- 8. Returns and Cancellations:** Return requests must be made within 90 days of shipment, and no product may be returned without a prior written Returned Goods Authorization (RGA) form signed by Seller and freight prepaid by Purchaser. All standard materials returned are subject to a handling charge, freight in both directions, a 25% minimum restocking fee and charges for any required reconditioning, clean up or re-certification, unless otherwise specified in writing by Seller. All returned standard materials are subject to inspection and final disposition by Seller's quality department. Special material items, buyouts, and modified products are non-returnable. Overages, shortages and incorrect material claims must be made in writing within ten (10) days of receipt of goods. Cancellation of orders once placed with and accepted by Seller may be made only with its written consent. Cancellation of orders are subject to a cancellation charge to be determined by impact at time of cancellation or modification of order. Cancellation of non-standard material or excessive quantities as determined by Seller may incur up to 100% cancellation charge depending on stage of work in progress.
- 9. No Waiver:** Seller's failure to insist upon compliance with any of the terms, covenants, or conditions listed herein or to exercise any right hereunder shall not be construed as a waiver or relinquishment of the future performance of any such term, covenant or condition, or the future exercise of such right or a waiver or relinquishment or waiver of any other term, covenant or condition or the exercise of any other rights hereunder.
- 10. Drawings, Data and Confidential Information:** The weights, dimensions, capacities, prices, performance ratings and other data included in catalogues, prospectuses, circulars, advertisements, illustrated matter and price lists constitute a guide. These data shall not be binding except to the extent that they are by reference expressly included in the purchase order. Any drawings or technical documents intended for use in the manufacture or construction of machinery, equipment, plants, parts, or other material and any ancillary services associated therewith, or any part thereof, and submitted to the Purchaser prior or subsequent to the formation of the purchase order (the "Material"), remain the exclusive property of the Seller; provided however, that the Material shall become the property of the Purchaser only if the Purchaser and Seller agree in writing. The Material shall not, without the Seller's consent, be utilized by the Purchaser or copied, reproduced transmitted or communicated to an unauthorized third party.
- 11. Governing Law:** This contract shall be governed by, construed and enforced in accordance with the laws of the State of Texas, without regard to its conflicts of law rules that would apply the laws of any other jurisdiction.
- 12. Totality of Agreement, Special Provisions, Modifications, Severability:** These Terms and Conditions constitute the entire agreement of the parties with respect to all matters and things herein mentioned. Purchaser warrants, represents and agrees that it has inspected the goods and otherwise made inquiry and review, upon its own behalf, concerning the nature, characteristics and quality of the materials and workmanship incorporated therein at or prior to delivery, that it is fully contented and satisfied therewith and has independently determined that the goods are in all respects fit and usable for all purposes for which they are intended to be employed by Purchaser. It is expressly acknowledged and agreed by and between the parties that neither party has, nor is now, relying upon any collateral, prior or contemporaneous agreement, written or oral, assurance or assurances, representations or warranties, of any kind or nature as to or respecting the condition or capabilities of the goods and the other matters and things, rights and responsibilities herein fixed and described. No modification, waiver or discharge of any term or provision of these Terms and Conditions shall be implied by law, nor shall any alteration, modification or acquittance of any such term or provision be effective for any purpose unless signed in writing by or on behalf of the party charged therewith. All products are subject to prior sales. All sales are subject to these [Terms & Conditions](#).
- 13. Export Regulations:** Seller's products can only be exported in accordance with U.S. Export Administration Regulations and other U.S. legal requirements. Diversion contrary to U.S. law is prohibited.

Represented By:



12735 Dairy Ashford Road
Stafford, Texas 77477
281.340.5400
Toll Free: 800.256.6193
Fax: 281.340.5499
www.globalflowtech.com