

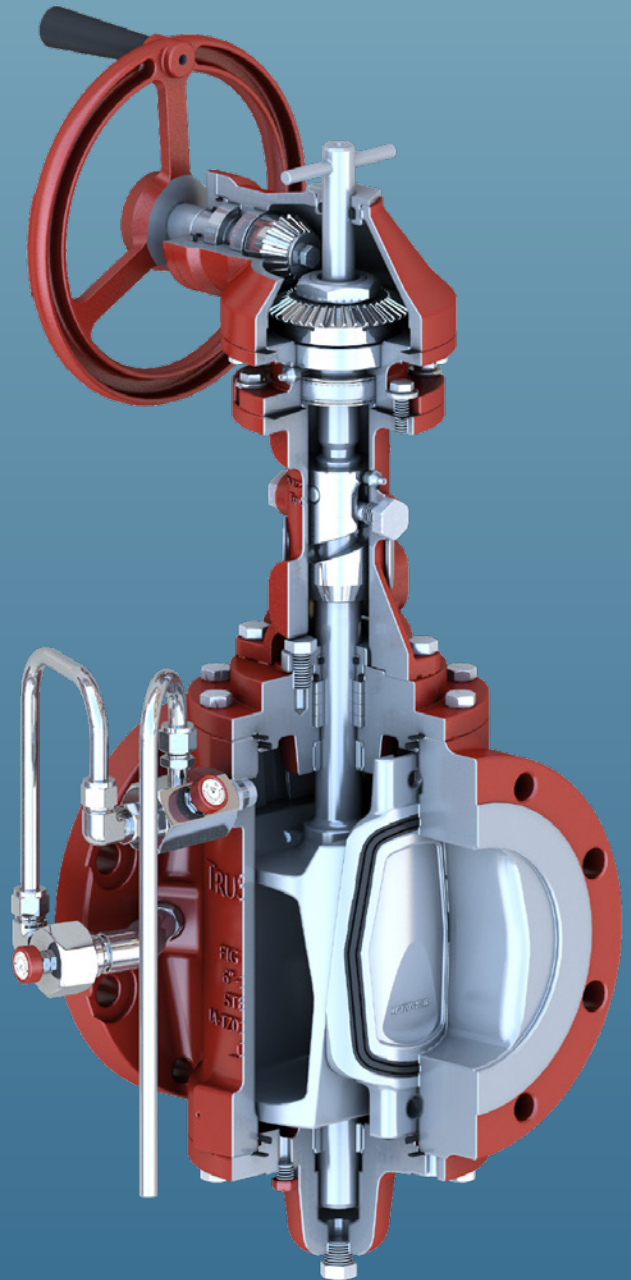

# GENERAL VALVE Twin Seal

Plug valve

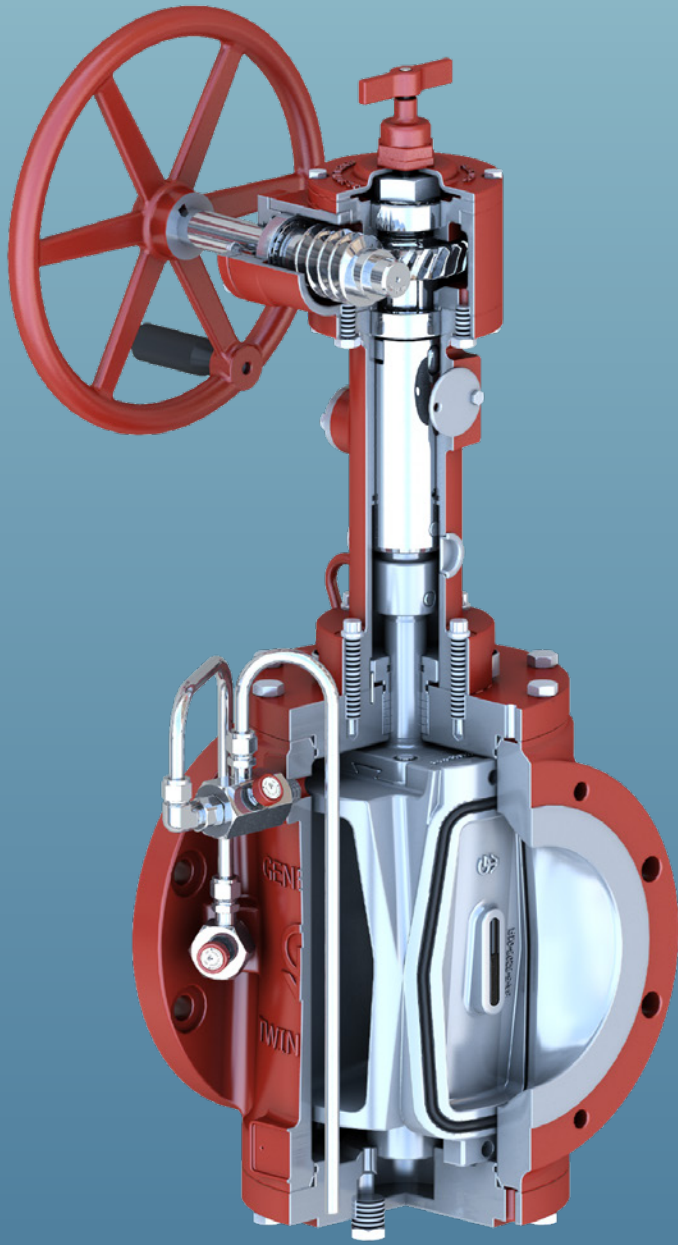

# Contents

Introduction .....	4
Evolution of double block-and-bleed valves .....	5
Zero-leakage double block-and-bleed plug valve with retracting seals .....	6
How the GENERAL VALVE Twin Seal* plug valve works .....	8
Twin seal valve configuration .....	10
Model 8800A features and benefits .....	11
<b>Dimensional tables</b>	
Model 200 .....	12
Model 8800A .....	13
Model 800 .....	14
Model 900 (fullbore, piggable) .....	15
Model 400 (short pattern) .....	16
<b>Accessories</b>	
GENERAL VALVE Twin Seal plug valve electric actuators .....	17
GENERAL VALVE Tru Seal* plug valve pneumatic actuators .....	18
Limit switches .....	19
Mechanical extensions .....	20
Direct burial—underground .....	21
Pressure-relief systems .....	22
Standard materials of construction .....	24
Services for valves and actuation .....	25

# Introduction

Cameron is a leading provider of valve, valve automation, and measurement systems to the oil and gas industry. Our products are primarily used to control, direct, and measure the flow of oil and gas as it is moved from individual wellheads through flowlines, gathering lines, and transmission systems to refineries, petrochemical plants, and industrial centers for processing.

Cameron provides a wide range of valves for use in natural gas, LNG, crude oil, and refined products transmission lines. The traditional CAMERON T30 Series\* fully welded ball valve product line has been combined with the GROVE\* valves, RING-O\* subsea valves, TOM WHEATLEY\* check valves, ENTECH\* nozzle check valves, and TK\* trunnion-mounted ball valve product lines. This broad offering has strengthened our ability to serve as a single source for a wide scope of customer requirements. We also provide critical service valves for refinery, chemical, and petrochemical processing businesses and for associated storage terminal applications, particularly through ORBIT\* rising stem ball valve, GENERAL VALVE\* plug and diverter valves, WKM\* valves, and TBV\* valve products.

Cameron is the world's leading manufacturer of high-integrity, positive-shutoff, double block-and-bleed valves, which serve the pipeline, liquid bulk terminal, aviation fueling, refining, oil and gas production, and custody transfer markets.



*Industry-leading manufacturing expertise and thorough QC: hallmarks of our globally distributed facilities, including Little Rock, Arkansas, USA.*

# Evolution of Double Block-and-Bleed Valves

Introduced in 1941, GENERAL VALVE Twin Seal\* plug valves were the first to meet the rigid requirements of double block-and-bleed service. In the years since, subtle yet significant design refinements have further improved valve performance. Superior design innovations, pride in manufacturing workmanship, and selection of the best materials support our commitment to excellence and customer satisfaction.

An alternative to the original two-valve system, the GENERAL VALVE Twin Seal plug valve has just one double-seated bubble-tight valve. The upstream and downstream seals provide the same function as the two block valves. The body serves as a spool piece and the body bleed verifies seal integrity.

## Scored seating segments

Seal abrasion is inherent in the design of most ball and gate valves. In most instances, the seats are ground or wedged against metal every time the valve cycles. Any foreign material lodged between the seats and ball or gate will score the seating surfaces. Once the seating segment is scored, product loss and contamination result. The GENERAL VALVE Twin Seal plug valve avoids abrasion by having both independent slips completely retracted from the body bore during cycling.



*Historical double block-and-bleed system requiring the use of two valves and a spool piece. A bleed valve was used to drain the spool and verify seal integrity.*

The GENERAL VALVE Twin Seal plug valve's completely retracted slip design minimizes leakage risk, reduces wear and maintenance, and saves money.

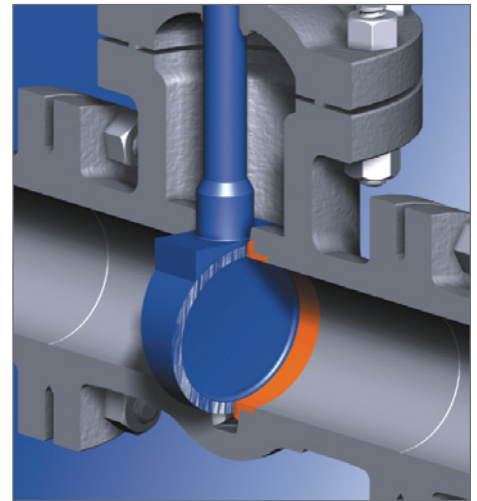

*Standard gate valve design (top). Standard trunnion mounted ball valve design (bottom).*

# Zero-Leakage Double Block-and-Bleed Plug Valve with Retracting Seals

In meter block service, the differential pressure across each closed valve is very low. No assistance is required from the line pressure to energize or compress floating seals to make them hold tight. The seals typically rely on springs to press them against the ball unless the body cavity in a ball valve is vented. The ball valve may be leaking until the user opens the bleed. Then, the reduction of the body pressure introduces a hydraulic force on the seat that may stop the leak. The user can form a false impression that the ball valve is holding tight, when in reality, it leaks.

In contrast, the mechanical wedge action of the valve plug compresses both the upstream and the downstream seals firmly against the valve body, needing no help from the line pressure. GENERAL VALVE Twin Seal plug valves hold with consistent and provable zero-leakage performance.

## Meter stations

Flowmeters require calibration to verify their accuracy. During meter calibration, every closed valve in the meter system must seal drop tight.

Even a small leak will cause errors in the meter calibration. The incorrect meter factor will persist until the next proving operation, and incorrect flow measurement can be costly. Every GENERAL VALVE Twin Seal plug valve in the meter station can be quickly and easily shown to be holding leak tight, ensuring consistently correct calibration.

## Multiproduct manifolds

The positive-shutoff GENERAL VALVE Twin Seal plug valve was developed for multiproduct fuel manifolds. Busy manifolds must be operated frequently, switching from product to product, often with power actuators and sometimes without supervision. Valves that can be trusted to seal drop tight every time will prevent the expensive consequences of contaminated fuel. By using GENERAL VALVE Twin Seal plug valves, gasoline, diesel, kerosene, jet fuel, heating oil, LPG, crude oil, and natural gas are protected from contamination.

*GENERAL VALVE Twin Seal plug valves for helping avoid contamination in multiproduct manifolds.*



### Tank storage isolation

Fuel in storage tanks is exposed to the risk of contamination and loss of volume unless the tank isolation valves can be checked for zero leakage. Tank-side valves are operated frequently, but ensuring tank integrity without GENERAL VALVE Twin Seal plug valves can be troublesome and expensive. Using line blinds (or skillet plates) for segregation involves a long, costly, and perhaps hazardous operation of draindown, lockout, and tagout. Traditional double block-and-bleed gate valves may produce loss of fuel from the open bleed. GENERAL VALVE Twin Seal plug valves offer simple, provable tank-side isolation, ensuring valve integrity.

### Hydrant isolation

Fuel hydrants at busy airports must be pressure tested regularly to check the integrity of the pipes, flanges, and gaskets. But the only time this inspection can be performed is when the airport is closed. On some occasions, sections of the hydrant must be isolated for extension, modification, or repair, or isolating section by section may be necessary to locate a leak.

GENERAL VALVE Twin Seal plug valves are the industry-recognized hydrant valves for hydrant isolation service because they

- close quickly and easily
- require very little maintenance
- hold with zero leakage
- hold a verifiable bubble-tight seal.

The hydrant pressure test can begin as soon as the valves are closed because the valves ensure that the hydrant is isolated.

### Fuel loading and unloading

Fuel loading and unloading may require hundreds of open and close strokes of the connection valves every day. The valves typically operate against full pump pressure on every stroke and must close without leakage.

Safety and environmental concerns demand that the fuel is absolutely contained within the pipe, yet the valves must operate quickly and easily. Many loading facilities depend on GENERAL VALVE Twin Seal plug valves for reliable, zero-leakage shutoff at rail, truck, and ship load manifolds. GENERAL VALVE Twin Seal plug valves have two resilient seals that fully retract from their seated position without seal rubbing, even at full differential pressure, reducing the effort required to operate the valve and eliminating slamming.

### Simple, inline field maintenance

A big advantage of the valve's design is that it permits inline servicing. Following simple removal of the valve bonnet or lower plate (after the line is depressurized and drained), all models can be repaired from top or bottom without removing the valve from the line. For further efficiency, Cameron offers a slip exchange program.



GENERAL VALVE Twin Seal plug valve model with safety bleed.

# How the GENERAL VALVE Twin Seal Plug Valve Works

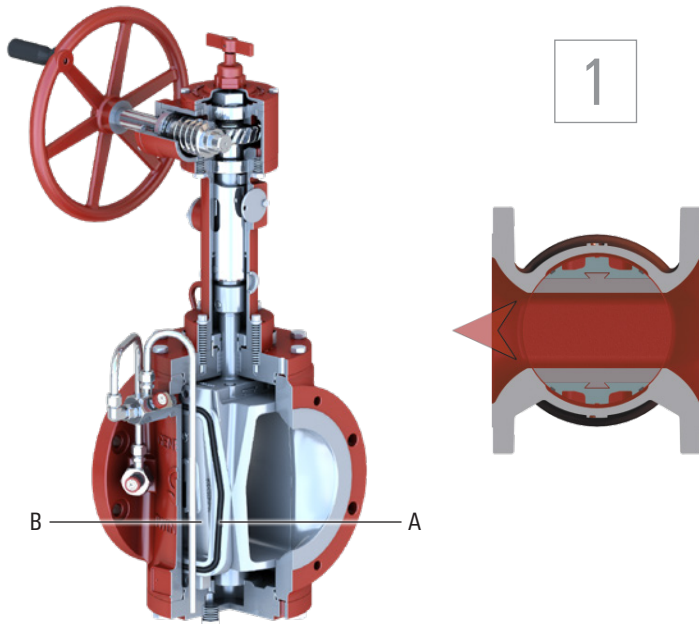

1. The seals (A) are permanently bonded into the slips (B), which are mounted on a central plug. In the open position, the slip seals are completely out of the flow.

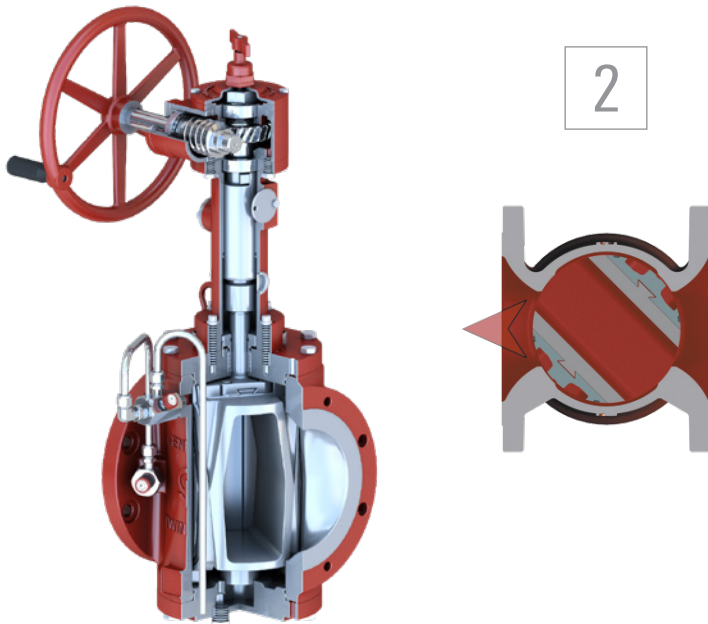

2. Turning the operator handwheel clockwise rotates the plug assembly 90° to block flow. During rotation, clearance is maintained between the seal and the valve body, enabling free movement and avoiding abrasion.



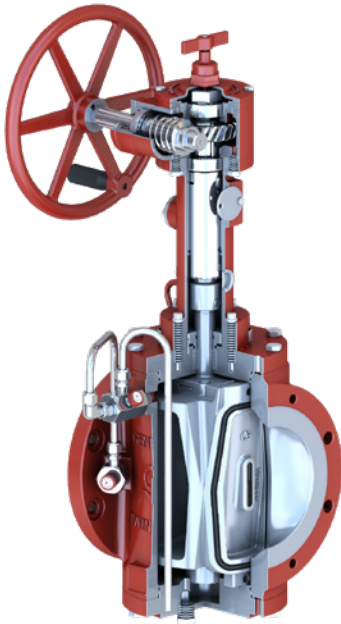

3

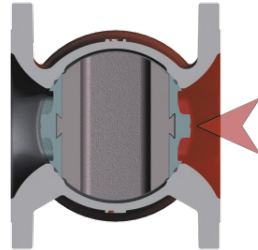

3. When the operator is turned farther clockwise, the tapered plug begins to lower, forcing the slips against the body and initiating the verifiable seal. Because its seals never drag in well-maintained valves, the GENERAL VALVE Twin Seal plug valve requires less torque to cycle.



4

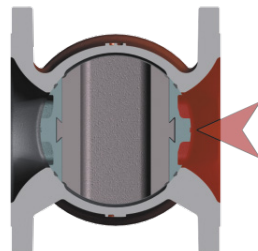

4. In the closed position, the slip seals are expanded, compressing the slip seals until metal-to-metal seating is effected. Because it is mechanical, the valve does not rely on line pressure differential to help make it seal and even seals in vacuum service.

**Note**

Do not attempt any repairs on valves unless you are certain the line pressure has been removed and the line contents have been drained from the valve, line, and body cavity. Failure to follow these instructions could result in injury to personnel or cause hazardous products to be vented from the valve. For complete instructions on installation and repair, request a copy of the valve installation manual from Cameron.

# Twin Seal Valve Configuration

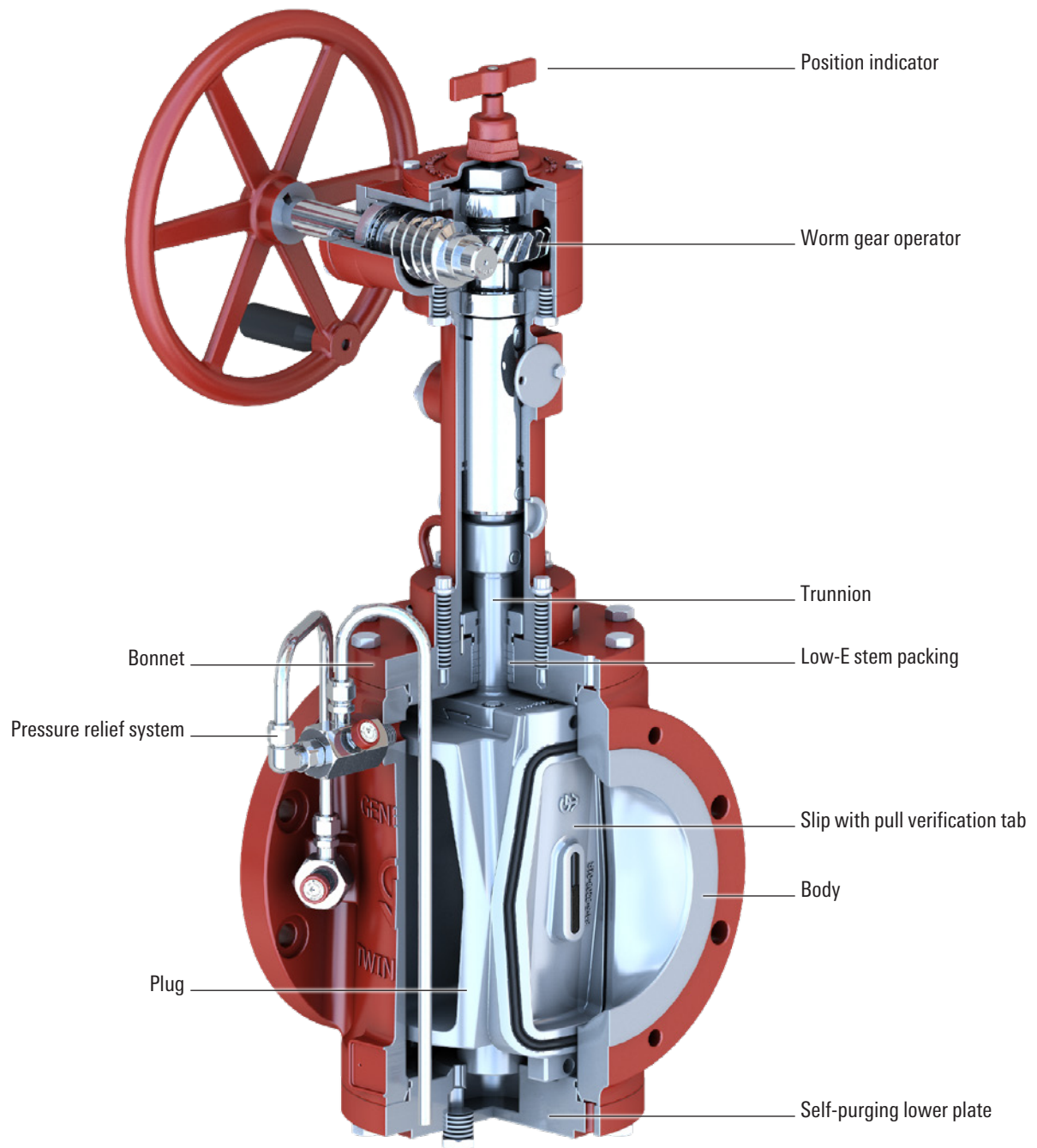

# Model 8800A Features and Benefits

## Low-E certified design

The GENERAL VALVE Twin Seal plug valve model 8800A offers fully fugitive emissions-qualified design as a standard with API 622 and 624 tested and qualified Low-E packing. The design is certified to ISO 15848-1 with the highest endurance class of C03.



## Modular plug

The patented modular plug design offers a redundant mechanical connection between the upper trunnion and plug to allow flexibility for upper trunnion material to meet customer needs. This unique design provides the ability to service and replace the trunnion in the field without replacing the entire plug.



## Slips with bond integrity pull tab

Manganese phosphate-coated slips eliminate surface corrosion and are available in more than 17 elastomers to meet most fluid needs. In-house bonding with slip bond integrity pull tab design ensures controlled quality and seal integrity. Slip exchange and a rebond program are available.



## Self-purging lower plate

The self-purging lower plate is specially designed to automatically flush the lower trunnion with each valve cycle, which prevents accumulation of particles and dirt in the lower part of the valve body. This design ensures consistent and reliable valve operation.

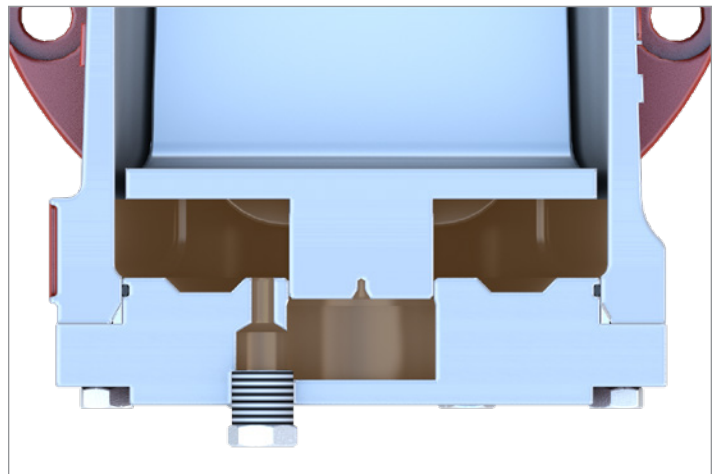

# Dimensional Tables

## Model 200

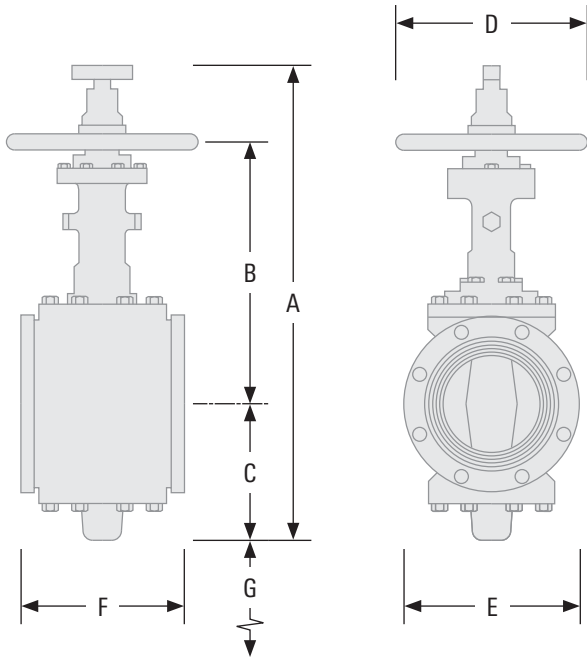

Model 200 (handwheel operated).

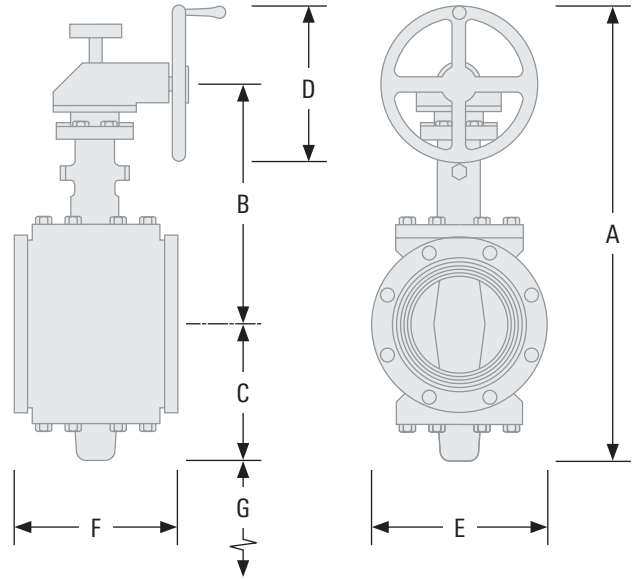

Model 200 (gear operated).

### Model 200 Specifications

	Size	Model	Operator	Maximum Overall Height	Centerline of Valve to Centerline of Handwheel	Centerline of Valve to Lowest Point	Hand-wheel Diameter	Flange Diameter	Face to Face	Minimum Clearance to Remove Slip from Bottom	Approx. Weight	Flow Coefficient (C <sub>v</sub> )
Class	in [mm]			A	B	C	D	E	F	G	lbm [kg]	galUS/min
ASME 150 handwheel operated	2 [50]	211	201	21¼ [540]	11⅞ [302]	5 [127]	10 [254]	6 [152]	7 [178]	3 [76]	60 [27]	200
	3 [80]	211	201	21¼ [540]	11⅞ [302]	5 [127]	10 [254]	7½ [191]	8 [203]	3 [76]	75 [34]	205
	4 [100]	211	201	23½ [597]	12⅝ [321]	6⅞ [162]	10 [254]	9 [229]	9 [229]	5 [127]	95 [43]	590
	6 [150]	211	202	31⅞ [790]	16¾ [426]	8⅝ [219]	14 [356]	11 [279]	10½ [266]	8 [203]	195 [88]	1,254
ASME 300 handwheel operated	2 [50]	221	201	21¼ [540]	11⅞ [302]	5 [127]	10 [254]	6½ [165]	8½ [216]	3 [76]	65 [29]	210
	3 [80]	221	201	21¼ [540]	11⅞ [302]	5 [127]	10 [254]	8¼ [210]	11⅞ [283]	3 [76]	90 [41]	220
	4 [100]	221	202	25⅞ [657]	15 [381]	5⅞ [130]	14 [356]	10 [254]	12 [305]	6 [152]	145 [66]	620
ASME 600 handwheel operated	2 [50]	241	202	24¾ [629]	13⅞ [353]	5⅞ [130]	14 [356]	6½ [165]	11½ [292]	3 [76]	115 [52]	290
	3 [80]	241	202	24¾ [629]	13⅞ [353]	5⅞ [130]	14 [356]	8¼ [210]	14 [356]	3 [76]	135 [61]	300
	4 [100]	241	203	31⅞ [810]	18 [457]	7⅞ [187]	16 [406]	10¾ [273]	17 [432]	4 [102]	240 [109]	850
ASME 150 gear operated	6 [150]	211	202G	31⅞ [810]	18¼ [464]	8⅝ [219]	10 [254]	11 [279]	10½ [267]	8 [203]	200 [91]	1,254
ASME 300 gear operated	4 [100]	221	202G	26⅞ [676]	16½ [419]	5⅞ [130]	10 [254]	10 [254]	12 [305]	6 [152]	155 [70]	620
ASME 600 gear operated	2 [50]	241	202G	25½ [648]	15⅝ [391]	5⅞ [130]	10 [254]	6½ [165]	11½ [292]	3 [76]	120 [54]	290
	3 [80]	241	202G	25½ [648]	15⅝ [391]	5⅞ [130]	10 [254]	8¼ [210]	14 [356]	3 [76]	140 [64]	300
	4 [100]	241	203G	33⅞ [861]	19½ [495]	7⅞ [187]	14 [356]	10¾ [273]	17 [432]	4 [102]	265 [120]	850

# Model 8800A

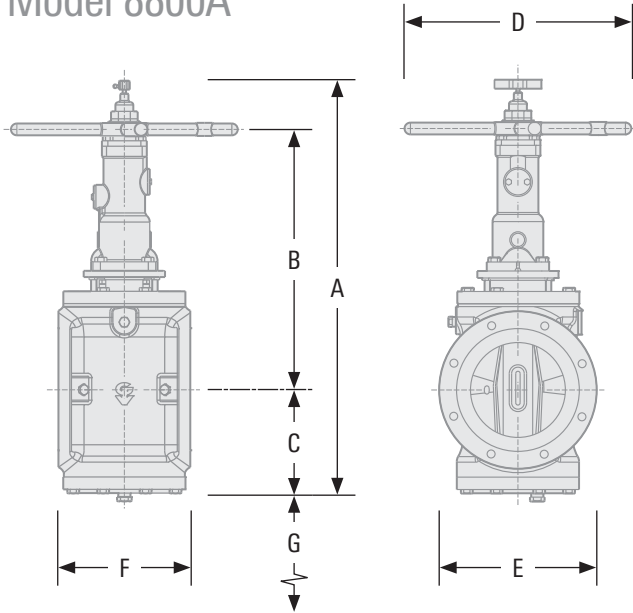

Model 8800A (handwheel operated).

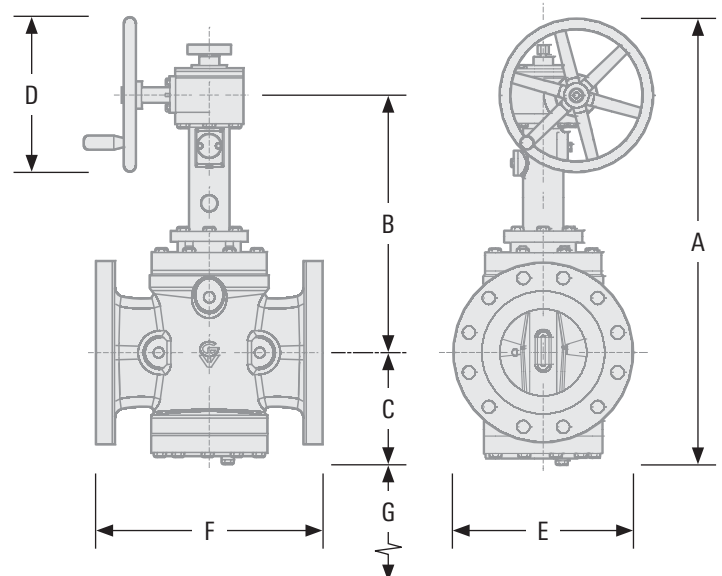

Model 8800A (gear operated).

## Model 8800A Specifications

	Size	Model	Operator	Maximum Overall Height	Centerline of Valve to Centerline of Handwheel	Centerline of Valve to Lowest Point	Hand-wheel Diameter	Flange Diameter	Face to Face	Minimum Clearance to Remove Slip from Bottom	Approx. Weight	Flow Coefficient (Cv)
Class	in [mm]			A,	B	C	D	E	F	G	lbm [kg]	galUS/min
ASME 150 handwheel operated	8 [200]	8811A	625H	36 [914]	23 [584]	9 [229]	20 [508]	13½ [343]	11½ [292]	12½ [318]	385 [175]	2,420
	6 [150]	8821A	625H	32½ [826]	21 [533]	7½ [191]	20 [508]	12½ [318]	15¾ [403]	9 [229]	250 [113]	1,770
ASME 150 gear operated	8 [200]	8811A	625G	39¾ [1,010]	23 [584]	9¾ [248]	14 [356]	13½ [343]	11½ [292]	12½ [318]	405 [184]	2,420
	10 [250]	8811A	625G	42 [1,067]	24 [610]	11 [279]	14 [356]	16 [406]	13 [330]	15 [381]	518 [235]	3,578
	12 [300]	8811A	751G	53 [1,346]	30½ [775]	13 [330]	20 [508]	19 [483]	14 [356]	17 [432]	790 [358]	4,000
	14 [350]	8811A	751G	56¼ [1,429]	31¾ [806]	14¾ [375]	20 [508]	21 [533]	15 [381]	19 [483]	995 [451]	5,500
	16 [400]	8811A	1261G	64 [1,626]	38 [965]	16¼ [413]	20 [508]	23½ [597]	16 [406]	22 [559]	1,340 [608]	7,000
	18 [450]	8811A	1261G	64¼ [1,632]	38 [965]	16¼ [413]	20 [508]	25 [635]	17 [432]	23 [584]	1,407 [638]	7,000
	20 [500]	8811A	1261G	68 [1,727]	39¾ [1,010]	16¼ [413]	20 [508]	27½ [699]	32 [813]	26 [660]	2,860 [1,297]	15,700
	24 [600]	8811A	1261G	72¾ [1,848]	41½ [1,054]	21½ [546]	20 [508]	32 [813]	36 [914]	28 [711]	3,830 [1,737]	24,000
ASME 300 gear operated	30 [750]	8811A	1276G	101 [2,565]	54½ [1,384]	30 [762]	32 [813]	38¾ [984]	60 [1,524]	28 [711]	9,664 [4,384]	44,500
	36 [900]	8811A	1500G	126¼ [3,207]	76¼ [1,937]	34 [864]	32 [813]	46 [1,168]	60 [1,524]	33 [838]	14,363 [6,515]	63,000
	6 [150]	8821A	625G	36 [914]	21¼ [540]	7¾ [197]	14 [356]	12½ [318]	15¾ [403]	9 [229]	312 [142]	1,770
	8 [200]	8821A	751G	43 [1,092]	27 [686]	9 [229]	20 [508]	15 [381]	16½ [419]	11 [279]	587 [266]	3,000
	10 [250]	8821A	751G	50 [1,270]	28¾ [718]	11¾ [298]	20 [508]	17½ [444]	18 [457]	14½ [368]	825 [374]	3,550
	12 [300]	8821A	1261G	58½ [1,486]	34½ [876]	13¾ [349]	20 [508]	20½ [521]	19¾ [502]	16¼ [413]	1,192 [541]	4,550
	16 [400]	8821A	1261G	69 [1,753]	40 [1,016]	18½ [470]	20 [508]	25½ [648]	22 [559]	24 [610]	2,254 [1,023]	7,000
	20 [500]	8821A	1276G	86¾ [2,203]	48 [1,219]	22½ [572]	32 [813]	30½ [775]	39 [991]	17½ [445]	4,381 [1,987]	16,650
ASME 600 gear operated	24 [600]	8821A	1276G	92 [2,337]	50½ [1,283]	25½ [648]	32 [813]	36 [914]	45 [1,143]	21¾ [552]	6,180 [2,803]	30,150
	30 [750]	8821A	1500G	120¾ [3,067]	73 [1,854]	31½ [800]	32 [813]	43 [1,092]	55 [1,397]	28 [711]	13,180 [5,978]	45,300
	6 [150]	8841A	751G	46½ [1,181]	27 [686]	9½ [241]	20 [508]	14 [356]	22 [559]	9 [229]	632 [287]	1,800
	8 [200]	8841A	751G	49 [1,245]	28¼ [718]	10¾ [273]	20 [508]	16½ [419]	26 [660]	12 [305]	1,007 [457]	3,300
	10 [250]	8841A	1261G	55 [1,397]	33 [838]	11¾ [298]	20 [508]	20 [508]	31 [787]	13¼ [337]	1,656 [751]	4,725
	12 [300]	8841A	1261G	63½ [1,613]	37¼ [946]	16 [406]	20 [508]	22 [559]	33 [838]	10½ [267]	2,144 [972]	7,300
	16 [400]	8841A	1276G	81½ [2,070]	45¾ [1,162]	20 [508]	32 [813]	27 [686]	39 [991]	26¼ [667]	3,990 [1,810]	11,800
	20 [500]	8841A	1500G	108¾ [2,762]	67¼ [1,708]	25½ [648]	32 [813]	32 [813]	47 [1,194]	15 [381]	7,940 [3,601]	18,600
24 [600]	8841A	1500G	115 [2,921]	71 [1,803]	28 [711]	32 [813]	37 [940]	55 [1,397]	19¾ [502]	10,662 [4,836]	30,000	

# Model 800

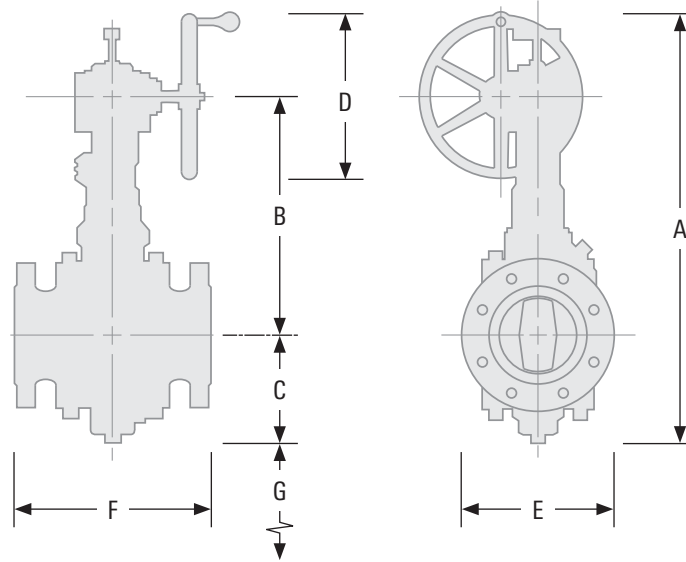

Model 800 (gear operated).

## Model 800 Specifications

	Size	Model	Operator	Maximum Overall Height	Centerline of Valve to Centerline of Handwheel	Centerline of Valve to Lowest Point	Hand-wheel Diameter	Flange Diameter	Face to Face	Minimum Clearance to Remove Slip from Bottom	Approx. Weight	Flow Coefficient (C <sub>v</sub> )
Class	in [mm]			A,	B	C	D	E	F	G	lbm [kg]	galUS/min
ASME 300 gear operated	14 [350]	C821	1261G	58½ [1,486]	34½ [876]	14½ [368]	20 [508]	23 [584]	30 [762]	15 [381]	1,990 [903]	6,000
	18 [450]	CA821	1261-7G	71 [1,803]	40½ [1,029]	20½ [521]	20 [508]	28 [711]	36 [914]	13 [330]	3,550 [1,610]	11,500
ASME 600 gear operated	14 [350]	C841	1276G	82½ [2,096]	47 [1,194]	19½ [495]	32 [813]	23¾ [603]	35 [889]	10 [254]	4,100 [1,860]	9,500
ASME 900 gear operated	2 [50]	C851	625G	33 [838]	19 [483]	7 [178]	14 [356]	8½ [216]	14½ [368]	3½ [89]	180 [82]	160
	3 [80]	C851	625G	34 [864]	19 [483]	8 [203]	14 [356]	9½ [241]	15 [381]	4 [102]	230 [127]	250
	4 [100]	C851	625G	37½ [953]	20 [508]	10 [254]	14 [356]	11½ [292]	18 [457]	6 [152]	397 [180]	650
	6 [150]	C851	755G	47½ [1,207]	26 [660]	11½ [292]	20 [508]	15 [381]	24 [610]	7½ [191]	975 [442]	2,400
	8 [200]	C851	1261-7G	63½ [1,613]	37 [940]	16½ [419]	20 [508]	18½ [470]	29 [737]	10 [254]	1,440 [653]	4,200
ASME 1500 gear operated	10 [250]	C851	1276G	88½ [2,248]	51½ [1,308]	21 [533]	32 [813]	21½ [546]	33 [838]	10 [254]	3,600 [1,633]	5,500
	2 [50]	C861	625G	33 [838]	19 [483]	7 [178]	14 [356]	8½ [216]	14½ [368]	3½ [89]	180 [82]	160
	3 [80]	C861	625G	34 [864]	19 [483]	8 [203]	14 [356]	10½ [267]	18½ [470]	4 [102]	280 [127]	250

# Model 900 (Fullbore, Piggable)

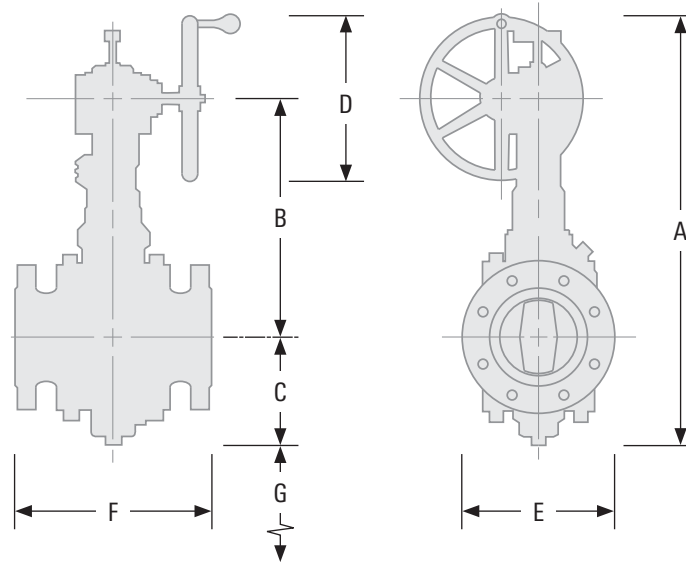

Model 900.

## Model 900 Specifications

	Size	Model	Operator	Maximum Overall Height	Centerline of Valve to Centerline of Handwheel	Centerline of Valve to Lowest Point	Hand-wheel Diameter	Flange Diameter	Face to Face	Minimum Clearance to Remove Slip from Bottom	Approx. Weight
Class	in [mm]			A	B	C	D	E	F	G	lbm [kg]
ASME 150	2 [50]	C911	501 TS	26 [660]	15 [381]	6 [152]	10 [254]	6 [152]	10½ [267]	5 [127]	216 [98]
	3 [80]	C911	501 TS	28 [711]	16 [406]	7 [178]	10 [254]	7½ [191]	13½ [343]	5 [127]	320 [145]
	4 [100]	C911	501 TS	32 [813]	17½ [445]	7 [178]	10 [254]	9 [229]	17 [432]	5 [127]	401 [182]
	6 [150]	C911	625 TS	37 [940]	21 [533]	9 [229]	14 [356]	11 [279]	21 [533]	7½ [191]	522 [237]
	8 [200]	C911	751 TS	48 [1,219]	27½ [699]	10½ [267]	20 [508]	13½ [343]	25 [635]	9 [229]	861 [390]
	10 [250]	C911	751 TS	52½ [1,334]	29 [737]	13½ [343]	20 [508]	16 [406]	31 [787]	11 [279]	1,275 [578]
	12 [300]	A1911	1261 TS	60 [1,524]	35 [889]	15 [381]	20 [508]	19 [483]	36 [914]	14 [356]	1,670 [757]
	14 [350]	C911	1261 TS	61½ [1,562]	36 [914]	15½ [394]	20 [508]	21 [533]	34 [864]	15 [381]	2,406 [1,091]
	16 [400]	C911	1261 TS	64 [1,626]	37 [940]	17 [432]	20 [508]	23½ [597]	35 [889]	17 [432]	3,006 [1,363]
	18 [450]	C911	1261.7 TS	78 [1,981]	44½ [1,130]	23½ [597]	20 [508]	25 [635]	48 [1,219]	18 [457]	5,700 [2,585]
20 [500]	C911	1261.7 TS	78½ [1,994]	44½ [1,130]	24½ [622]	20 [508]	27½ [699]	48 [1,219]	17 [432]	6,165 [2,796]	
24 [600]	C911	1276 TS	108½ [2,756]	60½ [1,537]	32 [813]	32 [813]	32 [813]	60 [1,524]	30 [762]	12,800 [5,806]	
ASME 300	2 [50]	C921	501 TS	26 [660]	15 [381]	6 [152]	10 [254]	6 [152]	11½ [283]	5 [127]	350 [159]
	4 [100]	C921	501 TS	29½ [749]	16½ [419]	7½ [191]	10 [254]	10 [254]	18 [457]	6 [152]	365 [165]
	6 [150]	C921	625 TS	38 [965]	21 [533]	10 [254]	14 [356]	12½ [318]	22 [559]	8 [203]	615 [279]
	8 [200]	C921	1261 TS	55 [1,397]	33 [838]	12 [305]	20 [508]	15 [381]	27 [686]	9 [229]	1,255 [569]
	10 [250]	CA921	1261 TS	58½ [1,486]	34½ [876]	14 [356]	20 [508]	17½ [445]	32½ [826]	12 [305]	1,800 [816]
	12 [300]	CA921	1261.7 TS	59 [1,499]	35 [889]	14 [356]	20 [508]	20½ [521]	38 [965]	16 [406]	2,500 [1,134]
	16 [400]	C921	1276 TS	83 [2,108]	48 [1,219]	19 [483]	32 [813]	25½ [648]	35 [889]	16 [406]	4,000 [1,814]
	18 [450]	C921	1276 TS	106½ [2,705]	67 [1,702]	23½ [597]	32 [813]	28 [711]	48 [1,219]	15½ [394]	6,400 [2,903]
20 [500]	CA921	1276 TS	89½ [2,273]	50½ [1,283]	23 [584]	32 [813]	30½ [775]	48 [1,219]	19 [483]	7,000 [3,175]	
ASME 600	2 [50]	C941	625 TS	32½ [826]	19 [483]	6½ [165]	14 [356]	6½ [165]	13 [330]	6 [152]	400 [181]
	4 [100]	C941	625 TS	34 [864]	19½ [495]	8 [203]	14 [356]	10¼ [273]	17 [432]	6 [152]	610 [277]
	6 [150]	C941	751 TS	47 [1,194]	27 [686]	10½ [267]	20 [508]	14 [356]	22 [559]	8 [203]	1,100 [499]
	8 [200]	C941	1261 TS	63 [1,600]	37 [940]	16 [406]	20 [508]	16½ [419]	26 [660]	10 [254]	2,150 [975]
	10 [250]	C941	1261 TS	64½ [1,638]	38½ [978]	16 [406]	20 [508]	20 [508]	31 [787]	12 [305]	3,100 [1,406]
	12 [300]	C941	1276 TS	83 [2,108]	47 [1,194]	19½ [495]	32 [813]	22 [559]	33 [838]	10 [254]	4,200 [1,905]
	14 [350]	C941	1500 TS	106 [2,108]	66 [1,676]	26 [660]	32 [813]	27 [686]	39 [991]	15 [381]	9,500 [4,309]
	16 [400]	C941	1500 TS	106 [2,692]	66 [1,676]	24 [610]	32 [813]	27 [686]	39 [991]	16 [406]	9,500 [4,309]
20 [500]	C941	1500 TS	114 [2,896]	72 [1,829]	29½ [749]	32 [813]	32 [813]	55 [1,397]	20 [508]	14,000 [6,350]	

## Model 400 (Short Pattern)

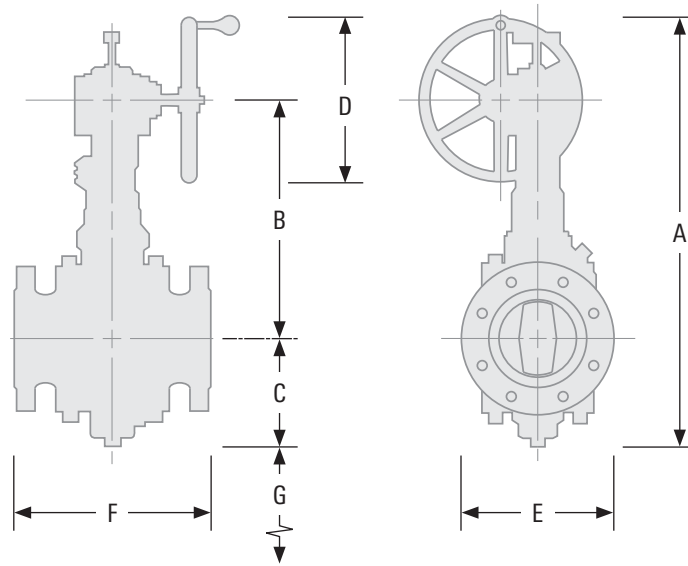

Model 400.

### Model 400 Specifications

	Size	Model	Operator	Maximum Overall Height	Centerline of Valve to Centerline of Handwheel	Centerline of Valve to Lowest Point	Hand-wheel Diameter	Flange Diameter	Face to Face	Minimum Clearance to Remove Slip from Bottom	Approx. Weight	Flow Coefficient ( $C_v$ )
Class	in [mm]			A	B	C	D	E	F	G	lbm [kg]	galUS/min
ASME 150	18 [450]	C411	1261 TS	67 [1,702]	38½ [978]	18 [457]	20 [508]	25 [635]	17 [432]	17 [432]	1,488 [675]	7,000
	20 [500]	C411	1261 TS	70 [1,778]	40 [1,016]	20 [508]	20 [508]	27½ [699]	18 [457]	22 [559]	2,658 [1,206]	8,500
	24 [600]	C411	1261 TS	74½ [1,892]	42½ [1,080]	22 [559]	20 [508]	32 [813]	20 [508]	28 [711]	3,326 [1,509]	11,250
ASME 300	24 [600]	C421	1276 TS	78.45 [1,993]	44.61 [1,133]	18 [457]	32 [813]	36 [914]	45 [1,143]	22 [559]	4,475 [2,030]	15,700
ASME 600	18 [450]	C441	1276 TS	82½ [2,096]	47 [1,194]	19½ [495]	32 [813]	29¼ [743]	39 [991]	10 [254]	4,300 [1,950]	10,200



# GENERAL VALVE Twin Seal Plug Valve Electric Actuators

GENERAL VALVE Twin Seal plug valves accept most commercially available multiturn electric motor operators.

All automated valves require some form of body pressure relief because of thermal expansion; otherwise, the valve can be difficult to open or may stick in the closed position.

## Choice of motor size

The best selection of valve, gearing, and motor operator depends on a number of factors, including

- pipeline pressure
- operating speed
- environmental conditions
- handwheel accessibility
- available power.

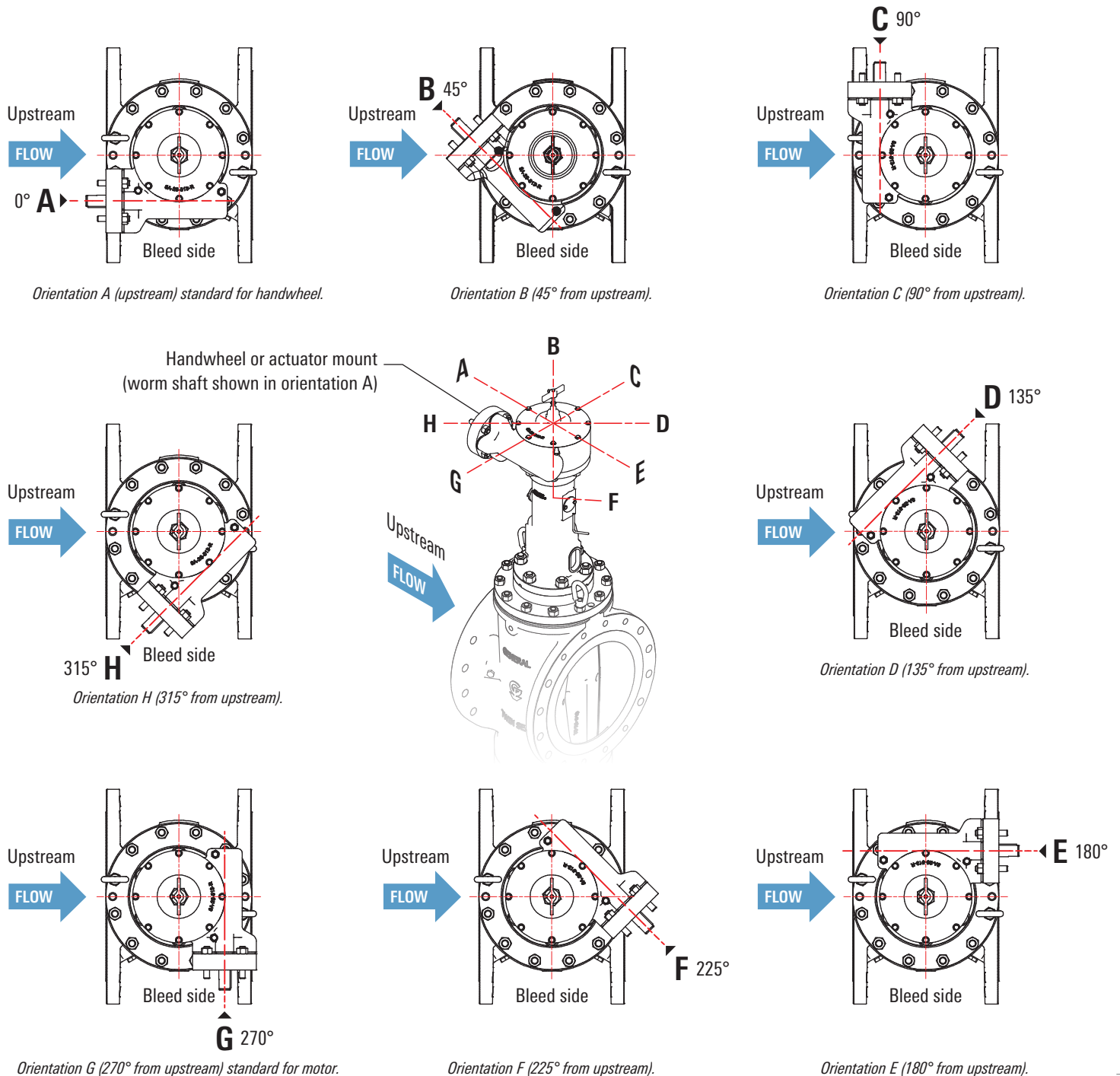

# GENERAL VALVE Tru Seal Plug Valve Pneumatic Actuators

Cameron builds pneumatic actuators that can be fitted to its valves for reliable, economic power operation. When you specify a complete actuated valve package, the entire system is built, tested, and guaranteed.

## Spring-close piston actuators

- Emergency shutdown (ESD) service
- Air to open (spring to close)
- Gas and oil speed control snubber system and two-way manual override handwheel
- Ability to mechanically lock valve closed or open
- Limit switches that can be fitted for remote indication of the valve position



## Double-acting diaphragm actuator with reservoir tank

- For continued operation in case of air supply failure
- Piston-type grease snubber for speed control
- Position indicator limit switches for local and remote indication of valve position
- Complete instrumentation package for
  - Fail close
  - Fail in last position



## Spring-close diaphragm actuator

- Air to open (spring to close)
- Integral gas and oil speed control snubber system
- Position indicator limit switches for local and remote indication of valve position
- Complete instrumentation package for
  - Close on loss of air supply
  - Close on loss of signal
  - Open on command
  - Close on command
- Pressure gauge for proof of zero-leakage shutoff



# Limit Switches

GENERAL VALVE Twin Seal plug valves can be fitted with switches or sensors to provide open and close position indication of the valve. The switches or sensors are housed within a proprietary enclosure that meets the latest national and international electrical and explosion-proof standards.



*GENERAL VALVE Twin Seal plug valve fitted with enclosed limit switches.*

# Mechanical Extensions

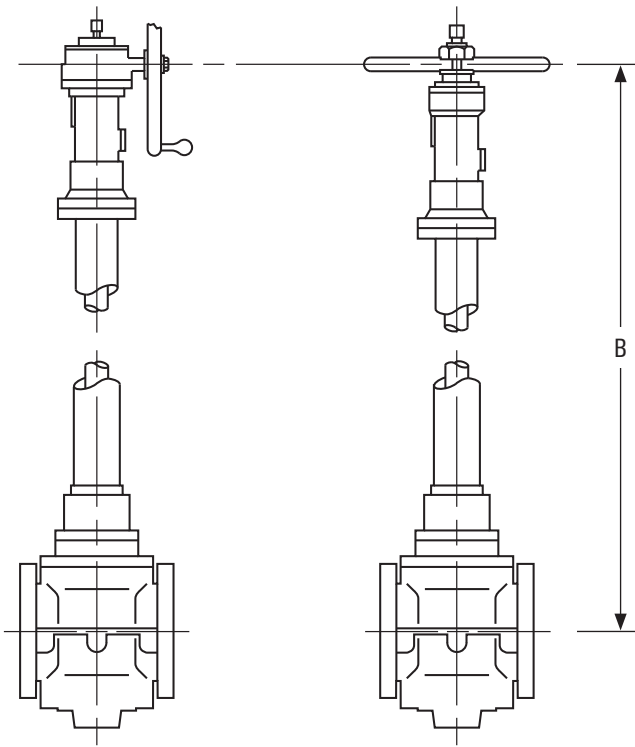

*Gear operator extension—  
closed type A.*

*Hand operator extension—  
closed type A.*

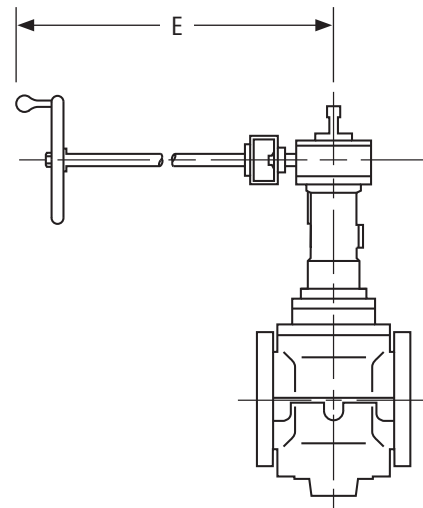

*Gear operator extension—  
lateral type C.*

The GENERAL VALVE Twin Seal plug valve product line provides both vertical and lateral extensions or combinations of both. When ordering, specify dimension B or E.

Type A extension is suitable for underground burial. Type C extension should be supported if dimension E is larger than 36 in [900 mm].

These valves, both hand operated and gear operated, can be supplied with chainwheels to operate elevated valves from below.

The chainwheels have an extradeep channel in which the chain runs to ensure that the chain will not climb off the track. The chain is supplied fully trimmed to eliminate barbs and is galvanized to withstand corrosive conditions.

When ordering chainwheels, provide the size and series of the valve and the length of chain required.

# Direct Burial—Underground

Patented extended-bonnet GENERAL VALVE Twin Seal plug valves greatly simplify maintenance in underground applications while providing dependable double block-and-bleed shutoff.

## Easy, inexpensive maintenance

Once extended bonnet valves have been installed, maintenance can be performed from above ground without a pit and without excavating. Unbolting and lifting the bonnet raises the valve plug and slips to ground level. Slip replacement is quick and easy, and downtime is minimal. Once the slips have been replaced, the assembly is lowered back into position and the bonnet is bolted down.

Hydraulic extension systems are available for GENERAL VALVE Twin Seal plug valves for installations where standard type A, B, and C extensions are not practical. Because the self-contained hydraulic extension systems are manually or hydraulically operated, there are virtually no limitations on length and orientation.

The hydraulic extension for gear operators essentially is a hydrostatic transmission. The pump is driven by a handwheel, and the pressure created is transmitted to the hydraulic motor mounted on the gear operator. This approach gives the system designer maximum flexibility because the only connections between the handwheel and valve are hydraulic tubes. There is no limitation on the number of corners turned between the valve and handwheel.

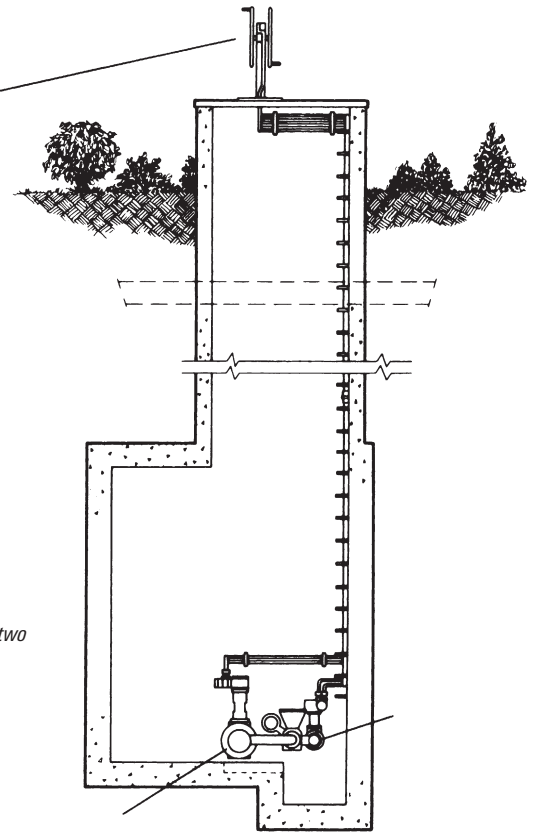
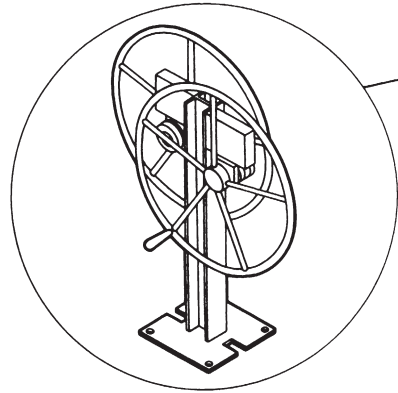

*Typical hydraulic extension system installation with two valves showing dual above-grade handwheel pump assemblies that are mounted on the same pedestal.*

# Pressure-Relief Systems

To satisfy the requirements of API Spec 6D, a pressure-relief device must be provided on all double block-and-bleed valves in liquid service. When the plug valve is seated and completely filled with liquid, even a slight increase in temperature caused by the sun's rays will result in a significant increase in the body cavity pressure resulting from thermal expansion. All GENERAL VALVE Twin Seal plug valves in liquid service must always be installed with a pressure-relief device.



## Manual bleed

A manual body bleed valve is included on this valve. This bleed valve installed in the body cavity is opened only after the GENERAL VALVE Twin Seal plug valve is closed. Seal effectiveness can be evaluated immediately. This bleed valve must be closed before the valve is reopened.



## Safety bleed and differential thermal relief (standard)

The differential thermal relief (DTR) system is arranged as shown. The integral relief valve, mounted in the upper relief and vent manifold, routes excess pressure to the upstream throat of the valve. The standard relief valve is set to open at 25 psi above upstream pressure. This system functions only when the valve is closed. A manual body bleed, also integrally mounted in the upper relief and vent manifold, is opened only to vent and to verify seal integrity. An isolation valve installed in the upstream throat tap also is included in this system. It must be left open to enable the relief system to relieve pressure upstream.



## Safety block and DTR

The safety block and DTR system functions exactly the same as the basic safety bleed. However, all working components are housed in a virtually indestructible, compact carbon steel manifold. The benefits of this incident-control equipment are fire safety, complete component access for maintenance purposes, all socket-welded joints, and heavyweight pipe and incident control.



#### Automatic body bleed valve

The automatic body bleed valve provides visual, positive assurance that the GENERAL VALVE Twin Seal plug valve has sealed at each cycling operation and prevents thermal pressure buildups in the body cavity. An automatic bleed valve connected to the body cavity of the main valve is mechanically opened by the valve operator when the valve is seated. Seal integrity is indicated by viewing the discharge of the bleed valve. When the valve is opened, the bleed valve is automatically closed by the combination of line pressure and the spring in the bleed valve.



#### Line-relieving safety bleed and DTR

The line-relieving differential thermal relief (LRDTR) system provides all the same features as a basic DTR system with one additional function—the pressure protects the downstream piping. A relief valve (25-psi differential pressure standard) is connected to the downstream throat tap via the lower tee. When the GENERAL VALVE Twin Seal plug valve is seated and the downstream piping is sealed bubble tight, the piping faces thermal overpressurization. The throat tap accesses this piping and directs any overpressurization upstream. An additional isolation valve is installed downstream for maintenance purposes.

# Standard Materials of Construction

Valve Series	200	8800A	400, 800, and 900
Body	Cast carbon steel ASTM A216 WCC <sup>†</sup>	Cast carbon steel ASTM A216 WCC <sup>†</sup>	Cast carbon steel ASTM A216 WCB <sup>†</sup>
Bonnet and lower plate	Carbon steel ASTM A216 WCC <sup>†</sup>	Carbon steel ASTM A516 Grade 70 <sup>‡</sup>	Carbon steel ASTM A516 Grade 70 <sup>‡</sup>
Plug	ASTM A216 WCC <sup>§</sup>	ASTM A216 WCC <sup>§</sup>	Cast carbon steel ASTM A216 WCB <sup>§</sup>
Stem	ASTM A216 WCC <sup>§</sup>	ASTM A705 17-4 ASTM A29, 4140	Cast carbon steel ASTM A216 WCB <sup>§</sup>
Slips	Manganese phosphate-coated ductile iron ASTM A395 Grade 60-40-18	Manganese phosphate-coated ductile iron ASTM A395 Grade 60-40-18	Manganese phosphate-coated ductile iron ASTM A395 Grade 60-40-18
Gland	ASTM A216 WCC	A487 CA6NM, A516 Grade 70; 24-in 600 <sup>‡</sup>	ASTM 487 CA6NM
Gland packing	Graphite	Graphite	Graphite
Body fire seals	Graphite	Graphite	Graphite
O-rings and slip seals	See trim selection	See trim selection	See trim selection
Fasteners	ASTM A193 Grade B7/2H	ASTM A193 B7/2H	ASTM A193 Grade B7/2H

Materials subject to change without notice

<sup>†</sup> Chrome-plated bore

<sup>‡</sup> Or industry equivalent

<sup>§</sup> Electroless nickel coated

Proper seal selection includes a number of considerations, such as media, pressure class, valve type, differential pressure, low temperature, high temperature, seal type, and more. A selection of slip seal materials and a brief list of considerations is given.

## Fluoroelastomers slip seal materials<sup>†</sup>

	Material	Description	GVMPs
V	Viton	Our standard material since 1958	3037
V9	Viton 90-durometer	Standard HIDP	3042
VX	Viton Extreme	Viton with best chemical resistance	3055
VFR	Fiber-reinforced Viton	Optional HIDP	3033
VGf	Viton GF	Viton with enhanced chemical resistance	3043
VLT	PPE Low temp Viton	Low-temperature Viton	3056
VGLT	Viton GFLT	Low-temperature Viton GF	3044
VGLT9	Viton 90-durometer GFLT	HIDP low-temperature Viton GF	3059

## Nitrile elastomers slip seal materials

H	Nitrile	Our original standard material	3048
H9	Nitrile 90-durometer	HIDP nitrile	3049
LH	Low-temperature nitrile	Low-temperature nitrile	3050
LH9	Low-temperature nitrile	Low-temperature 90-durometer nitrile	3067
H5	Modified nitrile	Reformulated gasoline seal material	3053

## Specialty slip seal materials

E	Ethylene propylene	Resistance to ammonia but not hydrocarbon	3057
UHS	Fluorosilicone	High and low temperature	3032
AFL	Aflas	Amines, explosive decompression, steam, 450 degF [232 degC]	3045
GVX	VTR 6279	Ultrasistance to chemicals	3047
T	Teflon	Multiple uses	3041

All specifications and materials are subject to change without notice.

<sup>†</sup> For more information, request the GVMPs.



# Services for Valves and Actuation

Cameron is well positioned to quickly and efficiently deliver total aftermarket support with unmatched OEM expertise. Our highly skilled engineers and technicians are available around the clock to respond to customer queries, troubleshoot problems, and offer reliable solutions.

## **Easily accessible parts and spare valves**

- OEM spare valves, actuators, and parts (including non-Cameron brands)
- Handling, storage, packaging, and delivery
- Dedicated stocking program

## **Comprehensive services portfolio**

- Parts and spare valves
- Repair
- Field services
- Preventive maintenance
- Equipment testing and diagnostics
- Remanufacturing
- Asset preservation
- Customer property management
- Training and recertification services
- Warranty

## **Customized total valve care programs**

- Engineering consultancy
- Site management
- Flange management
- Startup and commissioning
- Spare parts and asset management
- Operational support



# GENERAL VALVE Twin Seal



[products.slb.com/valves](https://products.slb.com/valves)

\*Mark of Schlumberger  
Other company, product, and service names  
are the properties of their respective owners.  
Copyright © 2019 Schlumberger. All rights reserved. 18-VL-291945

 **CAMERON**  
A Schlumberger Company