

TRICENTRIC®
Triple Offset Butterfly Valves

Excellent
Power & Industrial
Solutions



Superior performance for a wide range of applications



TRICENTRIC® is a leading brand of triple offset butterfly valves manufactured by Weir Valves & Controls USA, Inc. (“Weir Valves & Controls”).

TRICENTRIC® valves were the first triple offset butterfly valves to be introduced in North America in the late 1970s.

Weir Valves & Controls is part of The Weir Group PLC’s Power & Industrial Division. The Weir Group PLC is a FTSE 100 engineering solutions company headquartered in Glasgow, Scotland. The Weir Group’s global footprint covers over 70 countries, employing over 13,000 people. The Weir Group provides engineering solutions with a focus on the minerals, oil & gas and power markets.

Our rich history of engineering excellence gives us the knowledge base necessary to design valve products for the most demanding applications.

We serve customers across a broad range of industries including: conventional power, nuclear power, oil & gas, refining, desalination, chemical processing, pulp & paper mills, municipal service and special applications.



Motor operated valves in Ipswich, MA

Contents

Introduction	1
RAPID RESPONSE Program	1
Quality Assurance	1
Safety	2
Valve Testing	2
Conventional Power	3
Nuclear Power	4
Oil & Gas / Refining	5
Chemical Processing	5
Pulp & Paper	6
Municipal Service	6
Special Applications	6
Performance	7
Principle of Operation	8
Triple Offset Sealing System	8
Features & Benefits	9
Accessories & Options	10
Lug/Wafer Dimensions	11
Double Flanged Short Pattern	12
Double Flanged Long Pattern	13
Pressure Temperature Ratings	14
Standard Materials of Construction	16
Valve Data	17
Flow Coefficient (C _v)	
Torque Chart	
Weights	
Specification Summary	18
Ordering Information	19
Global Presence	21

The TRICENTRIC® brand is recognized in the market for excellent flow and control characteristics, sealing capabilities (zero leakage) and dependability in a wide range of applications.

TRICENTRIC® triple offset butterfly valves meet industry requirements and provide low cost of ownership to the end user through: improved life cycle costs, emissions control, less downtime and low maintenance costs.

The TRICENTRIC® brand is well known in the industry as a high quality metal seated valve that not only meets or exceeds engineering standards, but is also supported globally by a network of sales representatives, stocking distributors, service centers and trading hubs.

Our experienced sales engineers work closely with architect engineers, original equipment manufacturers and project managers to quote the specific product configurations required. Weir Valves & Controls' offerings were rated highly in the areas of sales knowledge, product reliability and product performance in a recent customer survey.* Weir Valves & Controls' aftermarket services were also rated highly by customers for knowledge of the product and responsiveness.

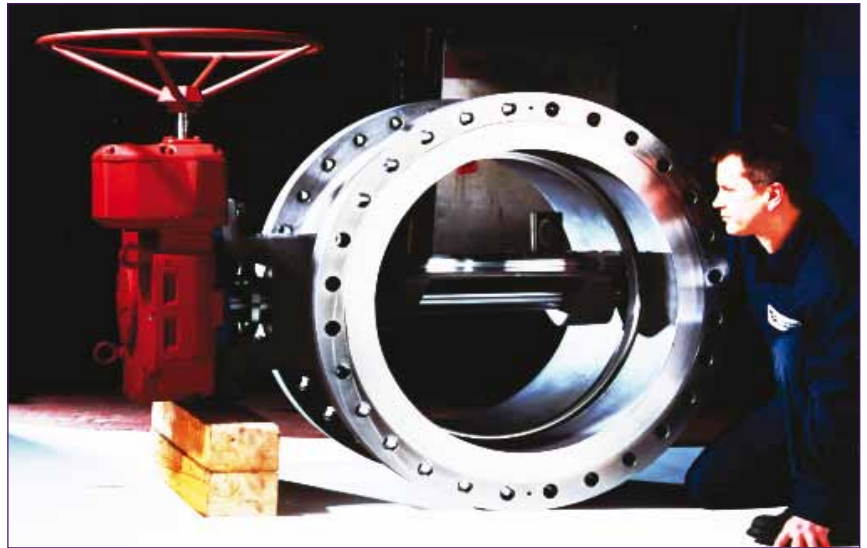

Final visual inspection of valve internals.

*"Weir Valves provided the engineering and service to the plant. The project manager and staff were engaged and that made the job easier."
– recent customer survey response*



**1-877-411 WEIR (9347)
RAPID RESPONSE PROGRAM**

Weir Valves & Controls supplies original equipment replacement parts at accelerated lead times through our RAPID RESPONSE program. We understand your needs in keeping the plant operating and your concerns when a failure occurs or a plant/system turnaround is scheduled. For this reason, parts can be delivered as quickly as 24 hours from inquiry. Our RAPID RESPONSE service is available for most TRICENTRIC® valve parts.

- Large stock of standard cast components.
- Quick turnaround on all non-standard castings.
- Genuine fully warranted OEM parts.
- Dedicated customer focused aftermarket organization.
- No compromise on OEM quality.
- OEM authorized service crews.

QUALITY ASSURANCE

Weir Valves & Controls implements and maintains quality programs to cover the full scope of its activities. Comprehensive quality systems have been developed to serve the power, oil & gas and industrial markets.

Weir Valves & Controls is certified with the following quality standards:

ISO 9001:2008

ISO 14001:2004

Pressure Equipment Directive 97/23/EC Module H

ASME Section III 'N' and 'NPT'

ASME NQA1

10 CFR50 App. B

Nuclear Utility Procurement Issues Committee (NUPIC)

An ongoing commitment to customer care is met through the process of continuous improvement and the further development of our systems and processes in accordance with ISO 9001:2008.

SAFETY

The company is committed to compliance with legislation and holds a certificate to OSHAS 18001:2007 for Environmental Health and Safety.

As part of The Weir Group PLC, Weir Valves & Controls has adopted a workplace safety system known as SAFESTART™, which has been rolled out in all facilities. All new employees are given this training as part of their induction.

VALVE TESTING

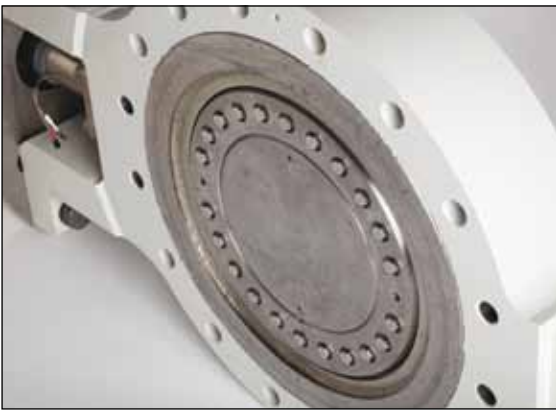

TRICENTRIC® valve showing view of clamp ring

Life Cycle

TRICENTRIC® valves have been tested extensively under a wide range of conditions in order to validate performance of the critical components (gasket, seal stack and bearing/shaft material). The overall design and tolerances were tested rigorously to meet industry life cycle standards.

Durability

Testing was also performed to establish the durability of the seal stack and validate the overall design.

Brackish Water

TRICENTRIC® valves were cycled using brackish water to validate the bearing/shaft combination and determine the effect of brackish water on standard components.

Cryogenic

TRICENTRIC® valves have proven seal reliability for liquid oxygen, liquid nitrogen, and liquid and natural gas services as required by NASA, the aerospace industry, oil field recovery services and other extreme applications.

In an independent laboratory test, after more than three hours submerged in liquid nitrogen at -321°F and 145 psig, the TRICENTRIC® valve met all the specification requirements, including zero leakage with helium.

TRICENTRIC® valves achieve tight shut-off, zero leakage at temperatures as low as -425°F in liquid oxygen, nitrogen and liquid natural gas applications.

Fire

TRICENTRIC® valves meet or exceed API 607.

Sulphur

TRICENTRIC® valves are designed to cut through solidified sulphur in seating and bearing areas with no seal damage or interruption of service.



Cryogenic testing

MARKETS SERVED

TRICENTRIC® valves are installed worldwide across a range of industries including:

- Conventional power
- Nuclear power
- Oil & gas / refining
- Desalination
- Chemical processing
- Pulp & paper mills
- Municipal service
- Special applications

Weir Valves & Controls has an extensive list of customer references, organized by market segments. The following lists are available from our Sales Department upon request:

- Chemical processing
- Geothermal steam
- Hydrocarbon processing
- Pulp and paper
- Steam
- Sulphur recovery and tail gas

Conventional Power

Regulatory compliance and fuel costs make operating efficiency a priority in this sector. Through superior products, service and support, Weir Valves & Controls is improving the availability and output of existing plants, from coal to combined cycle processes, helping our customers meet tough commercial and environmental targets. TRICENTRIC® product applications in conventional power settings include:

- Condenser cooling
- District heating and cooling
- Emergency heater drain
- Extraction steam isolation
- Fuel gas isolation
- Heat exchanger isolation
- Low pressure gate valve replacement
- Pump isolation
- Stop and control valves
- Suppression system



24" Cl. 150 body double flanged valve



"Quality products, with people to stand behind them."

– recent customer survey response

Nuclear Power

Nuclear plant operators are at the forefront of the effort to meet growing global demand for energy. Weir Valves & Controls' extensive nuclear expertise ranges from safety critical equipment design, to the supply of superior valve products, through to valve management and decommissioning.

The Weir Valves & Controls facility in Ipswich, MA holds ASME N and NPT Stamps for the manufacture of nuclear valves. TRICENTRIC® valves for use in nuclear applications are engineered to meet industry application needs. For envelope dimensions, flow coefficients and torques, please contact our Nuclear Sales Department at sales@weirvalveusa.com.

Applications in nuclear power include:

- Brackish cooling water
- Closed cooling water systems
- Condensate systems
- Containment isolation, including purge & vent
- Core spray systems
- Extraction steam isolation
- Fire protection system
- Heat exchanger isolation and controls
- Pump discharge isolation
- Saltwater service
- Service water system

Features and Benefits

- Over 2,000 TRICENTRIC® valves have been installed at nuclear plants worldwide including containment isolation and purge/vent applications
- Metal seal eliminates tearing, significantly minimizes seat wear and temperature radiation effects
- Torque Seated with Metal-to-Metal Seal = No Environmental Qualification Concerns, Longer Life
- Where TRICENTRIC® valves have replaced soft seated valves
 - Preventive maintenance frequencies have been extended
 - Maintenance costs have been greatly reduced
- Zero through-wall leaks
- Reliable, repeatable seating facilitates inline equipment isolation
- Superior sealing in comparison with other types of valves (gate, globe, high performance butterfly)
- Replacements of gate, ball, plug and soft seated butterfly valves with TRICENTRIC® valves has greatly improved system integrity; such plant applications include – condensate, SACS, demineralized water, containment purge & vent
- TRICENTRIC® is the proven triple offset butterfly valve for nuclear plants
- 30+ years of excellent service in BWR and PWR plants
- Selected for new Gen III Plants
- For a complete list of all TRICENTRIC® features, refer to page 9.



TRICENTRIC® valves are considered the standard for severe service butterfly valve applications in US nuclear power.

Oil & Gas / Refining

TRICENTRIC® valves are designed to all applicable standards in order to meet the demands of the refining industry: API 609 5th Edition and API 607.

Common oil & gas applications for TRICENTRIC® valves include:

- Ballast valve
- Co-generation
- Coker light ends
- Cryogenic LNG isolation
- Dirty hot cracking gas stop and control
- Dump valve (offshore)
- Flare gas hydrogen and sour gas control and isolation
- Fluidized catalytic cracker
- Fuel oil storage isolation
- Gasification air separation
- Gasoline
- Hydrogen processes
- Hydrotreating processes
- Light ends
- Molten sulphur
- Refinery desulphurization cooling water
- Reforming processes
- Steam supply stop and control
- Stop and control valves
- Sulphur condenser



A major gas turbine manufacturer has standardized on TRICENTRIC® triple offset butterfly valves for fuel gas safety shutoff.

Chemical Processing

Staying competitive in the global petrochemical market is all about the cost of production. The long life of TRICENTRIC® valves helps to reduce cost of ownership for the plant.

Typical applications in this market include:

- Acid gas
- Brine
- Caprolactam
- Chlorine gas
- CO₂ vapor
- Cooling water
- Emergency closure valves to isolate in one second or less
- Ethylene
- Flare inlet control and manifold isolation
- Furnace isolation
- Hot gases
- Hydrogen gas
- Liquid or gaseous oxygen
- Phenol
- Phosgene
- Propylene
- Process gas
- Steam
- Tail gas
- Vinyl chloride monomer (VCM)



"They are extremely responsive and provide a great service"

– recent customer survey response

Pulp & Paper

Global competition in pulp & paper mills means operators are looking for cost effective valves to stay up and running.

TRICENTRIC® valves can be found in all steps of the pulping process: the recovery area, stock prep, paper making and within the bleach plant.

TRICENTRIC® valve applications in the pulp & paper industry include:

- Alcohol reduction process
- Boiler water
- Demineralized water
- Digester gas off
- Green, red, black & white liquors
- Isolation and check valves for steam
- Lime mud slurries
- Mill water
- Oxygen systems
- Steam isolation
- Stock solutions
- Water treatment



Quarter turn operation, low maintenance and all metal construction make TRICENTRIC® valves ideally suited for severe service applications, such as green and black liquor.

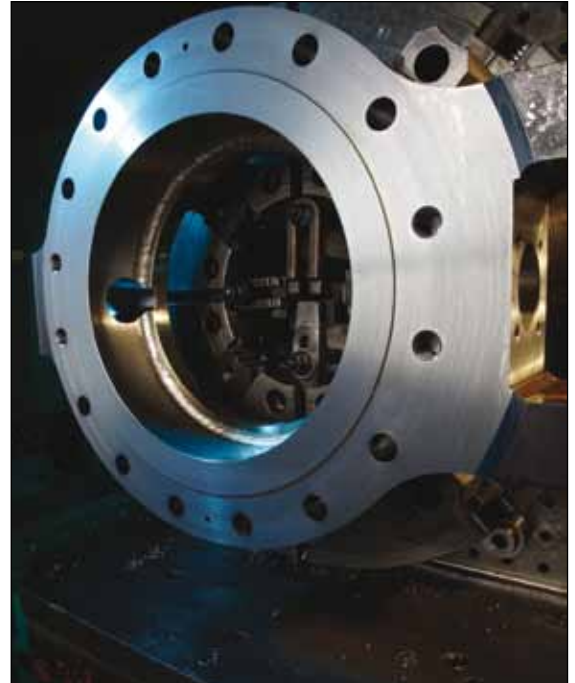

Valve body on machining center

*“Personnel are professional and dedicated.”
– recent customer survey response*

Municipal Service

In the municipal service sector, TRICENTRIC® valves are installed in the following areas:

- District heating
 - Hospitals
 - Universities
- Potable water
- Water/wastewater

Special Applications

- CO₂ recovery
- Cryogenic
- Food & beverage
- Geothermal plants
- High temperature gases and heated slurries, such as SO₂ and lime kiln feed
- Liquid oxygen
- Mining
- Molten sulphur
- Steam turbine stop and control valves

PERFORMANCE

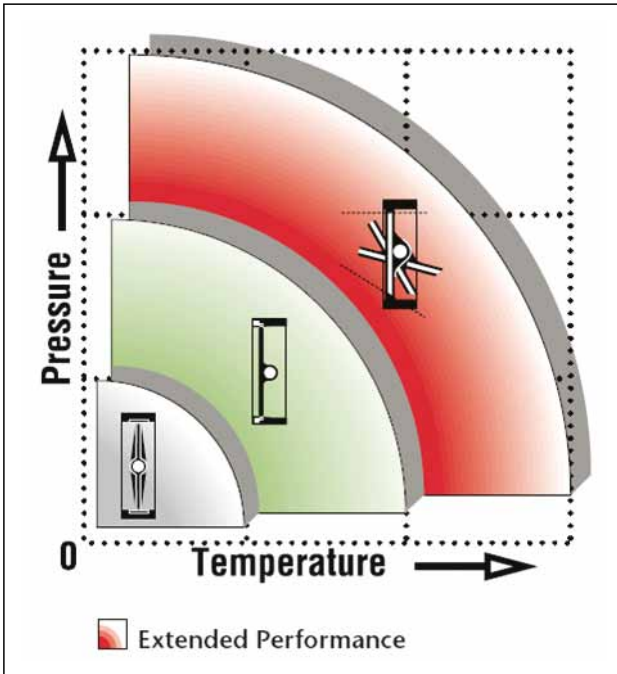

Single Offset
 Double Offset
 Triple Offset

Pressure/Temperature

TRICENTRIC® metal seated valves perform favorably when compared to conventional, resilient seated and high performance butterfly valves over all service ranges. TRICENTRIC® valves perform well especially at high pressure and temperature levels due to the following features:

- All alloy construction
- Flexible seal stack
- Non-rubbing metal seat
- Bubble tight shut-off
- Bi-directional, zero leakage
- Inherently fire safe

TRICENTRIC® valves have a long service history in nuclear power dating back to the late 1970's.

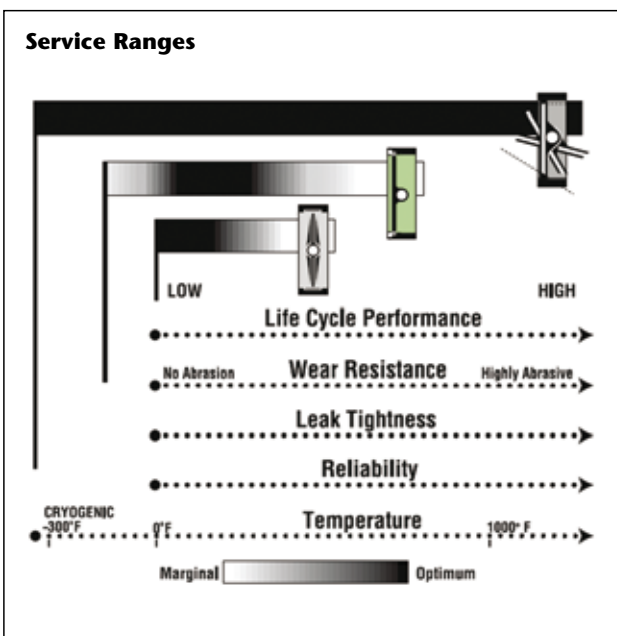

TRICENTRIC® Triple Offset Valves

TRICENTRIC® triple offset valves incorporate 3-way eccentricity. The metal seat is capable of very tight shut off at temperatures up to 1,500°F.

compared to:

HIGH PERFORMANCE (DOUBLE OFFSET)

The eccentric shaft results in an uninterrupted seal which can be used at higher pressures and temperatures. However, the resilient seats wear and can plug with solids.

compared to:

CONVENTIONAL (SINGLE OFFSET)

Center shaft which penetrates a resilient seal. Suitable for low temperature, low pressure services only.

PRINCIPLE OF OPERATION

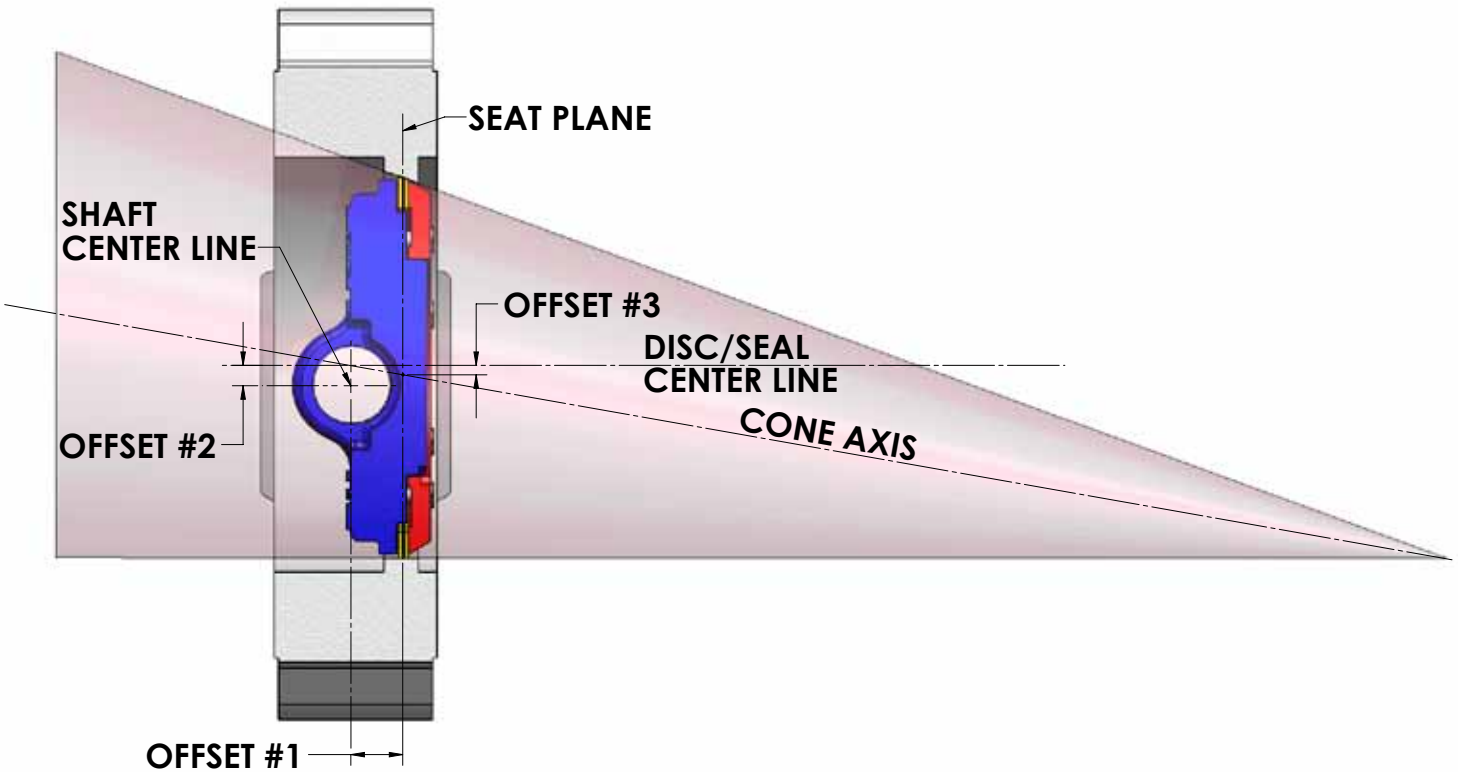

The principle of operation incorporated in the TRICENTRIC® triple offset valve is geometry in motion. Both the seat in the body and the seal on the disc are surfaces of a cone which is sectioned at an angle. The valve shaft is located slightly to one side of the seat center and above the plane of the seat. Its center of rotation is also somewhat offset from the axis of the imaginary cone which extends from the surface of the seat.

When the valve is closed, the surface of the seal and the seat are in full contact at all points. Any effort to try to further close the disc (rotating it into the seat) increases the sealing force and tightens the valve. This allows the valve to achieve a bi-directional seal.

Opening the valve, or rotating the disc away from its seat, results in the seal moving away from the seat at all points, eliminating rubbing or sliding of the seating surfaces, thus avoiding wear. TRICENTRIC® valves feature true non-rubbing seating surfaces for long life and tight shutoff.

TRIPLE OFFSET SEALING SYSTEM

- Offset #1 The shaft is offset from the seat plane providing an uninterrupted seating surface.
- Offset #2 Centerline of disc is offset from the centerline of the shaft allowing the seal to freely lift off and away from the seat on opening.
- Offset #3 The cone axis is offset from the centerline of the seal to provide a conical sealing surface that allows the seal to rotate in and out of the seat without interference, sliding or jamming.

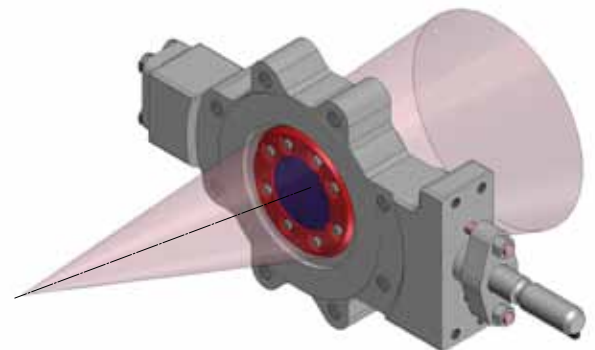

The TRICENTRIC® valve seal stack is designed to provide optimal sealing over the total product range. This is achieved by employing a laminated seal stack (stainless steel and graphite). The number of laminations depends on the size and pressure class and is critical to performance. For special applications, a solid seal is available.



TRICENTRIC® valve seal stack

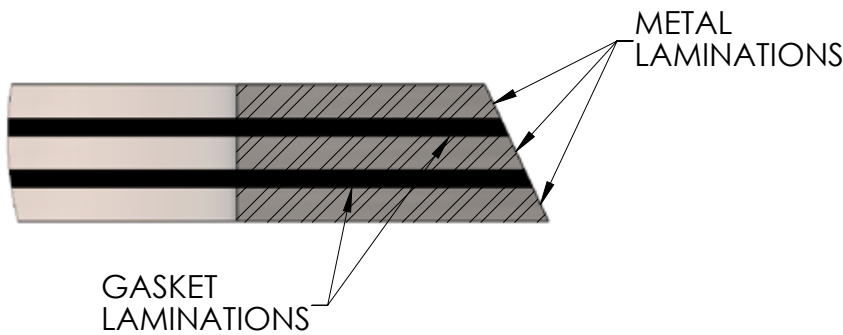

Features and Benefits

- Triple offset metal seat design
- Long life seats
- Bearing protectors
- Bi-directional tight sealing
- Zero leakage
- Excellent throttling characteristics
- Frictionless seating eliminates galling and/or seat and seal wear
- Shaft does not penetrate through seat/seal = less susceptible to seat leakage
- Shutoff is assisted by pressure = seating improves as pressure increases
- Seal is not subject to 'set' like soft seated designs = long term seating performance
- Torque seated, not position seated = No need to "find sweet spot" for seal
- Self compensating seal = will not stick due to temperature fluctuations
- Larger shaft diameter with more bearing wear surface = longer life
 - Robust shaft design to support full range of actuator torques

Design Standards / Criteria

- ASME B16.34
- ASME Section III
- GL 89-10 (NRC Generic Letter) Actuator Sizing
- GL 96-05 Periodic Verification Testing
- ASME QME-1 Mechanical Qualification

Pressure Classes

ASME CL. 150, 300 and 600

Sizes

3 – 96 in / 80 – 2,438 mm

Materials of Construction

- Carbon steels
- Alloy steels
- Stainless steels
- AL6XN
- Others available upon request

Features	Benefits
Metal to Metal Seating Surface	Inherently Fire Safe –400 to 1,500°F
Torque Seated	Zero Leakage
Third Offset and Conical Seat	Repeatable Seat Tightness, Seal Self Compensating during Thermal Cycling
Quarter Turn	Quick Opening & Closing

Body Type / End Connections

- Flanged
- Lugged
- Wafer
- Butt weld end
(end to end dimensions for BW valves can vary based on customer requirements)
- Special end to end requirements

Additional Options

- Oxygen clean and wrap
- Steam traced shaft
- Weld-on steam jacket
- Bolt-on steam jacket
- NACE MR 0175 & 0103 compliant
- PED / CE marking
- Heat extension bonnet
- Cryogenic extension bonnet
- Remote position indication
- Stem instrumentation
- Baseline diagnostic testing
- Live loaded packing
- Purge port and lantern ring
- Stellite seat overlay

Accessories

TRICENTRIC® valves are easily automated. A variety of automation options are available.



TRICENTRIC® valve with control accessories

Actuators

- Pneumatic
- Electric motor
- Hydraulic
- Manual gear

Actuator Accessories

- Actuator standoff designs
- Handwheel override
- Limit switches
- Solenoid valves
- Positioners



Pneumatically actuated TRICENTRIC® valve

Product Attribute	Design Standard
Valve Design	ASME B16.34 API 609 5th Edition ASME Sec III NC, ND (Nuclear)
Flange Design	ASME B16.5, B16.47
Butt Weld Design	ASME B16.25
Face to Face	ASME B16.10
Testing	ASME B16.34 API 598 API 607 QME1 ANSI/FCI 70-2 Class VI

Valve Body Styles Lug / Wafer

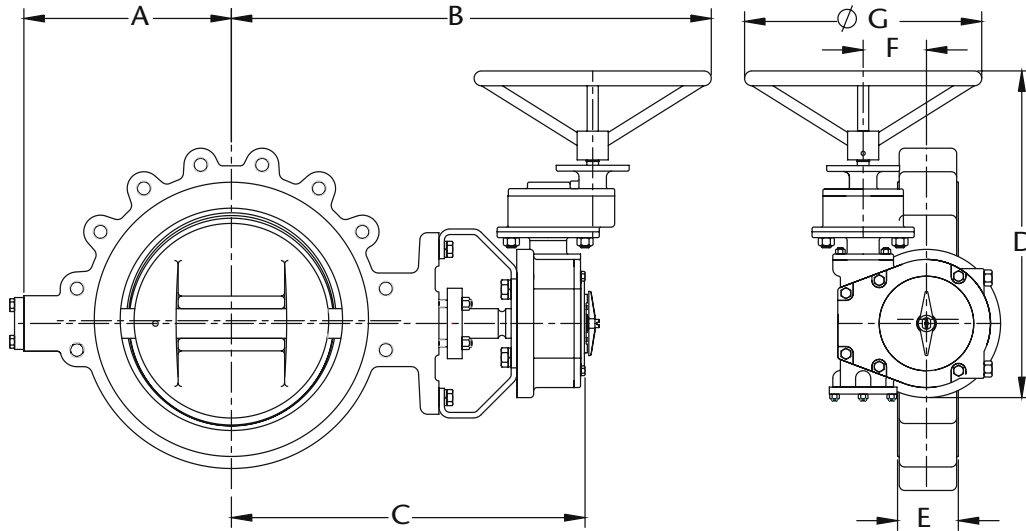

API 609 Category B TRICENTRIC® Valve Lug/Wafer Class 150 Dimensions

Size (in/mm)	A	B	C	D	E	F	G
3/80	6.66/169	15.49/393	12.81/325	9.90/251	1.88/48	1.97/50	8.00/203
4/100	7.41/188	16.06/408	13.58/345	9.97/253	2.13/54	1.97/50	8.00/203
6/150	8.39/213	17.34/440	14.68/373	12.78/325	2.25/57	2.58/65	8.00/203
8/200	9.66/245	23.09/586	17.43/443	14.78/375	2.50/63	2.58/65	14.00/356
10/250	10.91/277	24.48/622	19.28/490	14.92/379	2.81/71	2.81/71	14.00/356
12/300	12.41/315	30.88/784	20.65/525	18.13/460	3.19/81	3.58/91	24.00/610
14/350	13.41/341	35.51/902	21.90/556	20.34/517	3.63/92	4.07/103	30.00/762
16/400	14.66/372	32.88/835	24.51/623	23.04/585	4.00/102	4.27/108	16.00/406
18/450	15.41/391	35.63/905	25.26/642	24.04/611	4.50/114	4.27/108	20.00/508
20/500	16.66/423	37.96/964	27.10/688	26.06/662	5.00/127	5.24/133	20.00/508
24/600	18.94/481	39.55/1,005	30.32/770	29.30/744	6.06/154	5.79/147	24.00/610

API 609 Category B TRICENTRIC® Valve Lug/Wafer Class 300 Dimensions

Size (in/mm)	A	B	C	D	E	F	G
3/80	7.04/179	14.96/380	13.68/347	10.20/259	1.88/48	2.50/63	6.00/152
4/100	7.91/201	16.84/428	14.56/370	10.95/278	2.13/54	2.50/63	8.00/203
6/150	9.16/233	23.09/586	15.43/392	15.28/388	2.31/59	2.58/65	18.00/457
8/200	10.41/264	25.88/657	18.65/474	17.13/435	2.88/73	3.88/98	18.00/457
10/250	11.66/296	30.13/765	19.90/505	18.13/460	3.25/82	3.88/98	24.00/610
12/300	13.16/334	35.01/889	21.40/544	20.46/520	3.63/92	4.07/103	30.00/762
14/350	14.41/336	34.63/880	24.26/616	24.04/611	4.63/118	4.27/108	20.00/508
16/400	15.66/398	34.14/867	25.85/657	26.05/662	5.25/133	5.24/133	20.00/508
18/450	17.03/433	37.52/953	28.32/719	29.30/744	5.88/149	5.79/147	24.00/610
20/500	18.28/464	38.77/985	29.89/759	30.58/777	6.25/159	6.10/155	24.00/610
24/600	21.15/537	46.09/1,171	33.72/856	31.26/794	7.13/181	8.27/210	30.00/762

Valve Body Styles Double Flanged, Short Pattern

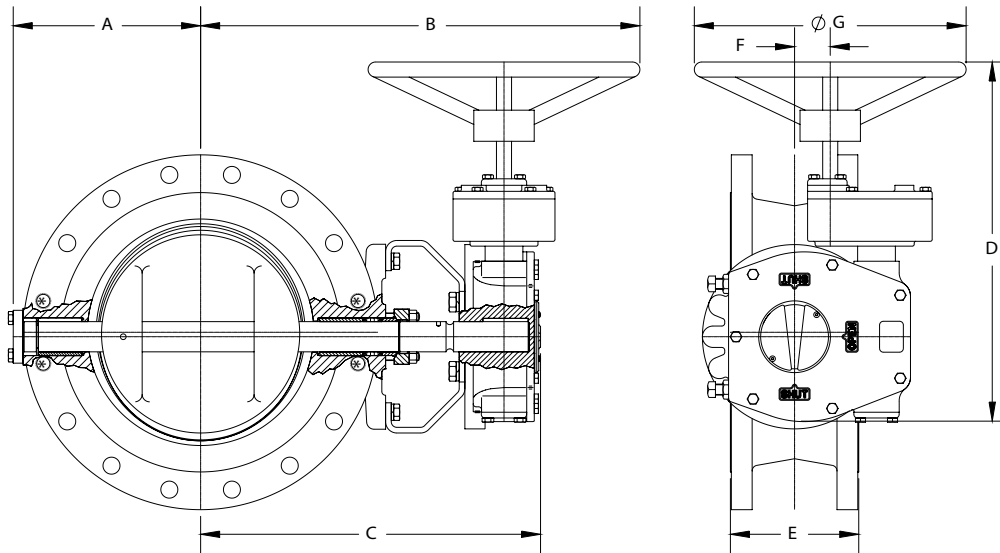

ISO 5752 TRICENTRIC® Valve Short Pattern Class 150 Dimensions

Size (in/mm)	A	B	C	D	E	F	G
3/80	4.80/122	13.62/346	10.94/278	9.97/253	4.44/113	1.97/50	8.00/203
4/100	5.25/133	14.44/367	11.96/304	9.97/253	5.00/127	1.97/50	8.00/203
6/150	7.00/178	16.09/409	13.43/341	12.78/325	5.51/140	2.58/65	8.00/203
8/200	8.19/208	21.59/548	15.93/405	14.78/375	6.00/152	2.58/65	14.00/356
10/250	9.47/241	23.36/593	18.16/461	14.92/379	6.50/165	2.81/71	14.00/356
12/300	10.94/278	29.44/748	19.21/488	18.13/460	7.00/178	3.58/91	24.00/610
14/350	11.18/284	33.64/854	20.03/509	20.34/517	7.50/190	4.07/103	30.00/762
16/400	12.44/316	31.13/791	22.76/578	23.04/585	8.50/216	4.27/108	16.00/406
18/450	13.44/341	34.51/876	24.14/613	24.04/611	8.75/222	4.27/108	20.00/508
20/500	14.88/378	36.96/939	26.10/663	26.06/662	9.00/229	5.24/133	20.00/508
24/600	17.50/444	39.33/999	30.13/765	29.30/744	10.50/267	5.79/147	24.00/610

ISO 5752 TRICENTRIC® Valve Short Pattern Class 300 Dimensions

Size (in/mm)	A	B	C	D	E	F	G
3/80	4.80/122	12.90/328	11.62/295	10.20/259	4.44/113	2.50/63	6.00/152
4/100	5.25/133	14.72/374	12.44/316	10.95/278	5.00/127	2.50/63	8.00/203
6/150	7.00/178	21.09/535	13.43/341	15.28/388	5.51/140	2.58/65	18.00/457
8/200	8.19/208	23.63/600	16.40/417	17.13/435	6.00/152	3.88/98	18.00/457
10/250	9.47/241	28.26/718	18.03/458	18.13/460	6.50/165	3.88/98	24.00/610
12/300	10.94/278	32.82/834	19.21/488	20.46/520	7.00/178	4.07/103	30.00/762
14/350	12.81/325	32.57/827	22.20/564	24.04/611	7.50/190	4.27/108	20.00/508
16/400	14.13/359	32.14/816	23.85/606	26.05/662	8.50/216	5.24/133	20.00/508
18/450	15.63/397	35.65/905	26.45/672	29.30/744	8.75/222	5.79/147	24.00/610
20/500	16.94/430	37.40/950	28.52/724	30.58/777	9.00/229	6.10/155	24.00/610
24/600	20.19/513	43.59/1,107	22.22/564	31.26/794	10.50/267	8.27/210	30.00/762

Valve Body Styles

Double Flanged, Long Pattern

Can directly replace gate valves in line - less weight, lower cost, easily automated

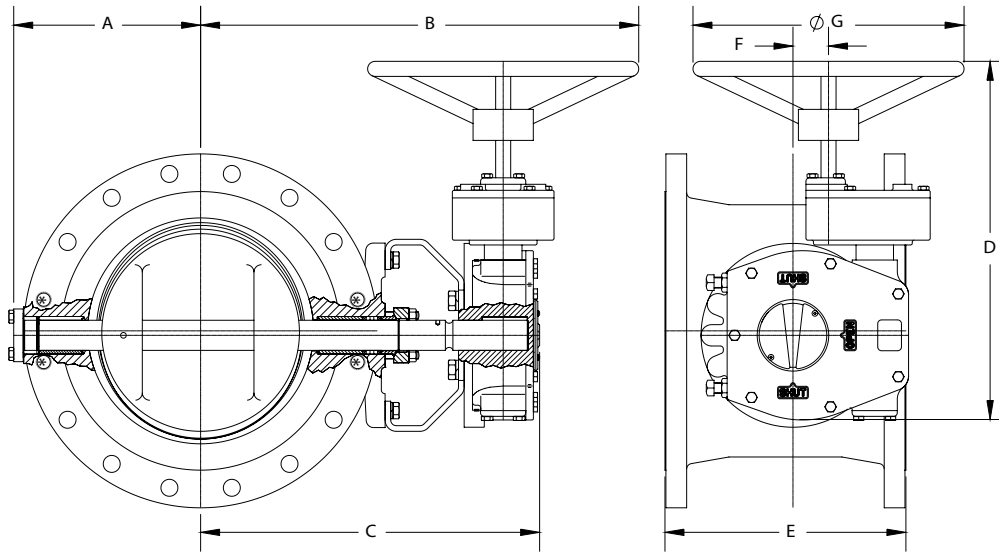

B16.10 TRICENTRIC® Valve Long Pattern Class 150 Dimensions

Size (in/mm)	A	B	C	D	E	F	G
3/80	4.80/122	13.62/346	10.94/278	9.97/253	8.00/203	1.97/50	8.00/203
4/100	5.25/133	14.44/367	11.96/304	9.97/253	9.00/229	1.97/50	8.00/203
6/150	7.00/178	16.09/409	13.43/341	12.78/325	10.50/267	2.58/65	8.00/203
8/200	8.19/208	21.59/548	15.93/405	14.78/375	11.50/292	2.58/65	14.00/356
10/250	9.47/241	23.36/593	18.16/461	14.92/379	13.00/330	2.81/71	14.00/356
12/300	10.94/278	29.44/748	19.21/488	18.13/460	14.00/356	3.58/91	24.00/610
14/350	11.18/284	33.64/854	20.03/509	20.34/517	15.00/381	4.07/103	30.00/762
16/400	12.44/316	31.13/791	22.76/578	23.04/585	16.00/406	4.27/108	16.00/406
18/450	13.44/341	34.51/876	24.14/613	24.04/611	17.00/432	4.27/108	20.00/508
20/500	14.88/378	36.96/939	26.10/663	26.06/662	18.00/457	5.24/133	20.00/508
24/600	17.50/444	39.33/999	30.13/765	29.30/744	20.00/508	5.79/147	24.00/610

B16.10 TRICENTRIC® Valve Long Pattern Class 300 Dimensions

Size (in/mm)	A	B	C	D	E	F	G
3/80	4.80/122	12.90/328	11.62/295	10.20/259	11.12/333	2.50/63	6.00/152
4/100	5.25/133	14.72/374	12.44/316	10.95/278	12.00/305	2.50/63	8.00/203
6/150	7.00/178	21.09/535	13.43/341	15.28/388	15.88/403	2.58/65	18.00/457
8/200	8.19/208	23.63/600	16.40/417	17.13/435	16.50/419	3.88/98	18.00/457
10/250	9.47/241	28.26/718	18.03/458	18.13/460	18.00/457	3.88/98	24.00/610
12/300	10.94/278	32.82/834	19.21/488	20.46/520	19.75/502	4.07/103	30.00/762
14/350	12.81/325	32.57/827	22.20/564	24.04/611	30.00/762	4.27/108	20.00/508
16/400	14.13/359	32.14/816	23.85/606	26.05/662	33.00/838	5.24/133	20.00/508
18/450	15.63/397	35.65/905	26.45/672	29.30/744	36.00/914	5.79/147	24.00/610
20/500	16.94/430	37.40/950	28.52/724	30.58/777	39.00/991	6.10/155	24.00/610
24/600	20.19/513	43.59/1,107	22.22/564	31.26/794	45.00/1,143	8.27/210	30.00/762

TRICENTRIC® Valve Material Pressure Temperature Ratings

Component		Material	Temperature Range (°F)	Maximum Body Pressure Rating at 100° F (psig)			Note
				CL 150	CL 300	CL 600	
Body & Disc	Standard	WCB – ASTM A216 (carbon steel)	-20 to 800	285	740	1480	1
		CF8M – ASTM A351 (316SST)	-425 to 1,500	275	720	1440	3, 4
	Optional	LCB – ASTM A352 (carbon steel low temp)	-50 to 650	265	695	1395	
		LCC – ASTM A352 (carbon steel low temp)	-50 to 650	290	750	1500	
		LC3 – ASTM A352 (carbon steel low temp)	-150 to 650	290	750	1500	
		WC6 – ASTM A217 (Cr-Mo steel)	-20 to 1,050	290	750	1500	2, 3
		WC9 – ASTM A217 (Cr-Mo steel)	-20 to 1,100	290	750	1500	2, 3
		CF8 – ASTM A351 (304 SST)	-425 to 1,500	275	720	1440	3, 4
		CF8C – ASTM A351 (347 SST)	-325 to 1,500	275	720	1440	3, 4
		CG8M – ASTM A351 (317 SST)	-425 to 1,000	275	720	1440	3
		CN7M – ASTM A351 (Alloy 20)	-325 to 600	230	600	1200	5
		CD4MCuN – ASTM A351 (Duplex)	-425 to 600	290	750	1500	
		CZ100 – ASTM A494 (Nickel)	-325 to 600	140	360	720	6
		CY40 – ASTM A494 (Inconel 600)	-325 to 1,200	290	750	1500	6, 3, 12
		M30C – ASTM A494 (Monel 400)	-325 to 900	230	600	1200	6, 13
		CW12MW – ASTM A494 (Hastelloy C)	-325 to 1,000	230	600	1200	5
		C95500 – ASTM B148 (Ni-Al-Bz)	-425 to 600	Contact Weir Valves & Controls Sales Rep			
		Grade 3 Titanium	-75 to 600	Contact Weir Valves & Controls Sales Rep			
Seat	Standard	316L SST overlay on carbon steel	per body material				
		Integral cast on stainless and exotic	per body material				
	Optional	ALLOY 6	-425 to 1,500				
		ALLOY 21	-425 to 800				
		INCOLLOY 825	-20 to 1,200				
Shaft	Standard	S17400 (17.4 PH DH1150) Full Rated	-325 to 850			7	
	Optional	316SST – Reduced Rated	-425 to 600			8, 11	
		ALLOY 20 – Reduced Rated	-325 to 800			8, 11	
		INCONEL 600 – Reduced Rated	-325 to 900			8, 11, 12	
		INCONEL 625 – Reduced Rated	-325 to 1,200			8, 11, 12	
		MONEL K500 – Full Rated	-325 to 900			11, 13	
		INCONEL 718/750 – Full Rated	-20 to 1,500			11, 12	
		Stainless or Exotic equal to body grade	per body material			8, 11	

TRICENTRIC® Valve Material Pressure Temperature Ratings (cont.)

Component		Material	Temperature Range (°F)	Maximum Body Pressure Rating at 100° F (psig)	Note
Seal Stack	Standard	316 SST Laminated with Graphite	-400 to 1,200		9
	Optional	316 SST Solid	-400 to 1,200		
		316 SST Solid with Stellite overlay	-400 to 1,500		14
		INCONEL 600 Laminated with Graphite	-20 to 1,200		9, 12
		INCONEL 625 Laminated with Graphite	-20 to 1,000		12
		MONEL 400 Laminated with Graphite	-400 to 900		9, 13
Bearings	Standard Wafer & Lug	CL 150, 300 and 600 – Nitronic 60	-325 to 1,500		10
	Standard Flanged	CL 150 and CL 300 – Graphite	-400 to 1,700		10
		CL 600 – Nitronic 60	-325 to 1,500		
	Optional	PTFE composition	-425 to 325		8
		CoCr – A	-425 to 1,500		
		Bronze	-425 to 600		8
		Ceramic composition	-20 to 2,500		8
Packing	Standard	J.C. 387I and Graphite	-400 to 1,200		9
	Optional	PTFE Chevron	-425 to 450		
		PTFE Braided	-425 to 450		

Notes:

1. Per ASME B16.34 – Permissible but not recommended for prolonged use above 800°F.
2. Per ASME B16.34 – Use normalized and tempered material only.
3. Per ASME B16.34 – Use of a flanged valve in CL150 ANSI above 1,000°F not recommended.
4. Per ASME B16.34 – At temperatures over 1,000°F, use only when the carbon content is 0.04% or higher.
5. Per ASME B16.34 – Use solution annealed material only.
6. Per ASME B16.34 – Use annealed material only.
7. Long exposure above 600°F may cause embrittlement.
8. Use of this material may result in a reduced differential pressure rating. Contact a Weir Valves & Controls sales representative for further information.
9. Upper temperature limit reduced to 850°F in oxidizing media.
10. Upper temperature limit reduced to 850°F in oxidizing atmosphere.
11. Upper temperature limit is specified as a general guide based on code, specification and minimum torsional seating requirements. Use of material above this limit may violate these requirements. Contact a Weir Valves & Controls sales representative for specific application material evaluation.
12. Inconel is a registered trademark of Huntington Alloys Corporation that refers to a family of austenitic nickel chromium-based superalloys.
13. Monel is a trademark of Huntington Alloys Corporation for a series of nickel alloys, primarily composed of nickel (up to 67%) and copper, with some iron and other trace elements.
14. Stellite is a trademark of Deloro Stellite Company. It is an alloy containing cobalt-chromium, tungsten, molybdenum and carbon.

Reprinted from ASME B16.34-2009, by permission of The American Society of Mechanical Engineers. All rights reserved. No further copies can be made without written permission.

Standard Materials of Construction

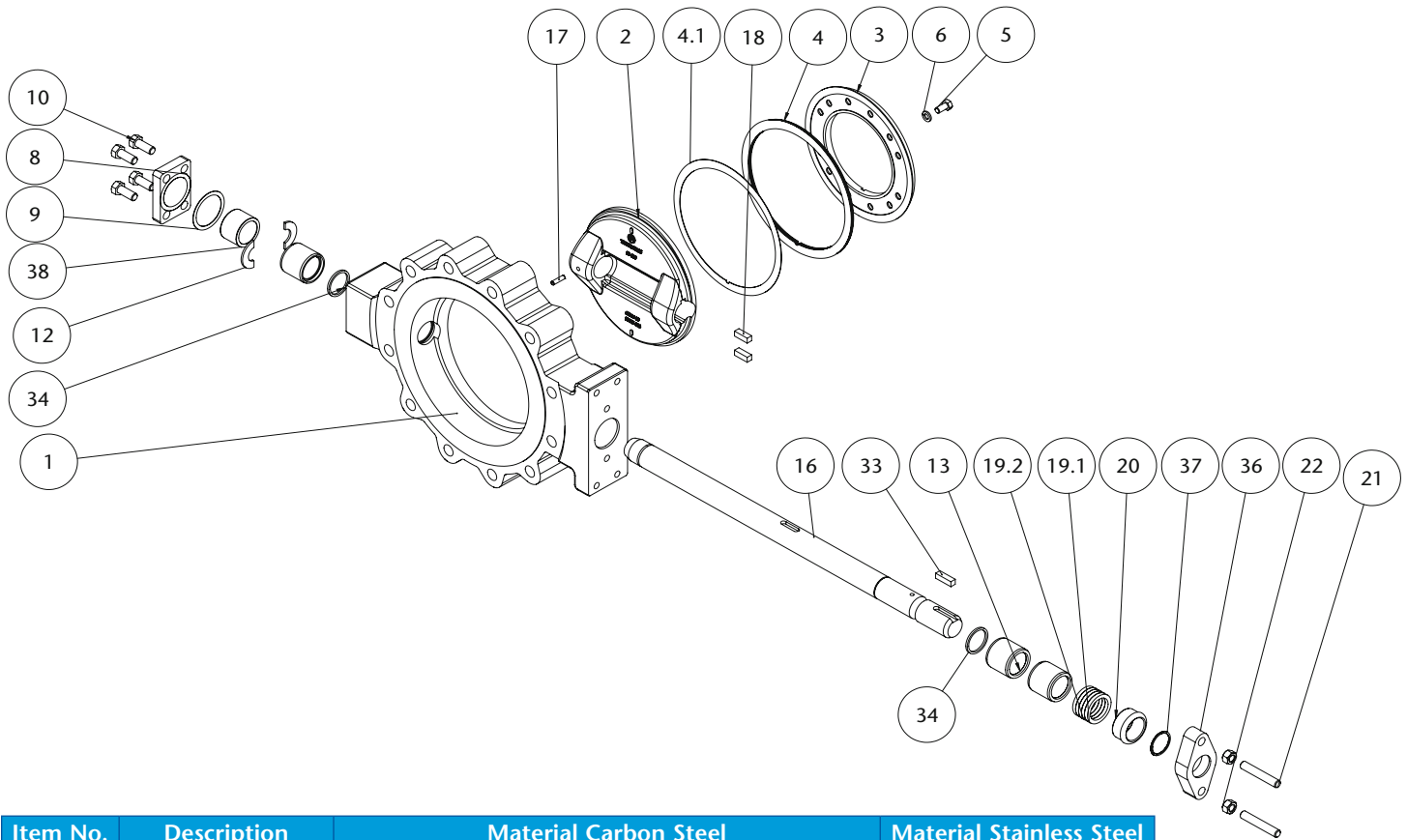

Item No.	Description	Material Carbon Steel	Material Stainless Steel
1	Body	Carbon Steel/A216 WCB with 316 SST Overlaid Seat	A351 GR CF8M
2	Disc	A351 CF8M (<14") • A216 GR WCB (>12")	A351 CF8M
3	Clamp Ring	A216 GR WCB (<14") • A351 CF8M (>12")	A351 CF8M
4	Seal Stack	A240 S31803/Graphite	A240 S31803/Graphite
4.1	Seal Gasket	Graphite	Graphite
5	HX, HD, Cap Screw	A193 B8M CL1	A193 B8M CL1
6	Lock Washer	316 SST	316 SST
8	Cover Plate	A351 CF8M (<14") • A216 GR WCB (>12")	A351 CF8M
9	Cover Plate Gasket	Graphite/SST	Graphite/SST
10	HX, HD, Cap Screw	A193 B8M CL1(<14") • A193 B7 GR WCB (>12")	A193 B8M CL1
12	Annular Key	A479 S21800	A479 S21800
13	Bearing	A479 S21800	A479 S21800
16	Shaft	A 564 630 H1150M	A 564 630 H1150M
17	Spring Pin	SST	SST
18	Parallel Key	A479 316 SST	A479 316 SST
19.1	Wiper Ring	Braided Graphite	Braided Graphite
19.2	Packing Ring	Die Formed Graphite	Die Formed Graphite
20	Gland Follower	A582 S41600	A582 S41600
21	Stud	A193 B8M CL1	A193 B8M CL1
22	Hex Nut	A194 8M	A194 8M
33	Actuator Key	A311 1045	A311 1045
34	BRG Protector	Braided Graphite	Braided Graphite
36	Gland Plate	A351 CF8M (<14") • A216 GR WCB (>12")	A351 CF8M
37	Retaining Ring	302 SST	302 SST
38	Spacer Ring	316 SST	316 SST

Valve Data

Maximum Flow Coefficient (C_v)

Valve Size (in/mm)	CL 150	CL 300	CL 600
3/80	112	112	
4/100	270	280	
6/150	780	770	495
8/200	1,530	1,280	1,030
10/250	2,550	2,190	1,680
12/300	3,990	3,510	2,540
14/350	5,300	4,700	3,300
16/400	6,950	6,300	5,230
18/450	9,230	8,750	7,100
20/500	12,700	10,700	9,100
24/600	18,300	17,000	14,200

Maximum Torque

Valve Size (in/mm)	CL 150 (FT-LB/N-M)	CL 300 (FT-LB/N-M)
3/80	100/136	192/260
4/100	188/255	317/430
6/150	354/480	625/847
8/200	508/689	1,125/1,525
10/250	708/960	1,417/1,921
12/300	1,500/2,034	1,838/2,492
14/350	2,000/2,712	3,417/4,633
16/400	2,417/3,277	4,609/6,249
18/450	3,167/4,294	6,500/8,813
20/500	4,083/5,536	8,583/11,637
24/600	6,500/8,813	13,938/18,897

Bare Stem Weight

Valve Size (in/mm)	CL 150 Lug (lb/kg)	CL 300 Lug (lb/kg)	CL 600 Lug (lb/kg)	CL 150 Wafer (lb/kg)	CL 300 Wafer (lb/kg)	CL 600 Wafer (lb/kg)	CL 150 Flanged (lb/kg)	CL 300 Flanged (lb/kg)	CL 600 Flanged (lb/kg)
3/80	33/15	41/19		22/10	39/18		65/30	80/36	
4/100	41/19	48/22		35/16	41/19		80/36	95/43	
6/150	62/28	78/35	124/56	55/25	60/27	100/45	95/43	130/59	150/68
8/200	93/42	134/61	208/94	82/37	104/47	154/70	150/68	180/82	250/113
10/250	139/63	189/86	311/141	111/50	141/64	226/103	208/94	295/134	340/154
12/300	215/98	271/123	443/201	170/77	201/91	328/149	322/146	450/204	550/249
14/350	283/128	484/220	735/333	230/104	317/144	535/243	428/194	753/342	750/340
16/400	380/172	635/288	885/401	330/150	414/188	700/318	547/248	1,040/472	950/431
18/450	460/209	835/379	1,268/575	370/168	551/250	950/431	636/288	1,340/608	1,300/590
20/500	614/279	1,071/486	1,560/708	467/212	687/312	1,040/472	725/329	1,560/708	1,640/744
24/600	923/419	1,559/707	2,340/1,061	727/330	1,067/484	1,820/826	1,165/528	2,480/1,125	2,450/1,111

Notes:

Torque values are based on maximum differential pressure.

Data provided in this catalog has been derived from a combination of testing and computational programs. Actual valve performance may be affected by a number of variables unique to the application.

Specification Summary

COMPONENT	WCB	CF8M
Body	A216 Gr WCB	A351 CF8M
Body Seat	316SST or Alloy 21 overlay	Integral or Alloy 21 Overlay
Disc	A351 CF8M or A216 Gr WCB	A351 CF8M
Seal	A240 S31803/Graphite	A240 S31803 (Duplex SST/Graphite)
Clamp Ring	A351 CF8M or A216 Gr WCB	A351 CF8M
Disc Fastener	A193 B8M CL1, 18-8SST	A193 B8M CL1 or 18-8SST
Disc Fastener Lockwasher	316SST	316SST
Cover Plate	A351 CF8M or A216 WCB	A351 CF8M
Cover Plate Gasket	Graphite/SST	Graphite/SST
Cover Plate Fastener	A193 B8M CL1 or A193 B7	A193 B8M CL1
Annular Key	A479 S21800 or Equivalent	A479 S21800 or Equivalent
Shaft Spacer Ring	316SST	316SST
Shaft Bearing	A479 S21800 or Equivalent	A479 S21800 or Equivalent
Drive Shaft	A564 630 H1150M	A564 630 H1150M
Disc Pin	Coiled/SST	Coiled/SST
Parallel Key, Disc	A479 S31600	A479 S31600
Shaft Packing	Braided & Die Formed Graphite	Braided & Die Formed Graphite
Gland Follower	A582 S41600	A582 S41600
Gland Stud	A193 B8M CL1	A193 B8M CL1
Gland Stud Hex Nut	A194 8M	A194 8M
Parallel Key, Actuator	A311 C1045	A311 C1045
Bearing Protector	Braided Graphite	Braided Graphite
Gland Plate	A351 CF8M	A351 CF8M
Shaft Retaining Ring	302SST	302SST

Note:

Other materials available upon request.

Ordering Information

Product Model Number Configuration Wafer & Lug Style (API STD 609, Category B)

VALVE SIZE	RATING CLASS	BODY STYLE & BODY/ DISC MATERIAL	SHAFT MATERIAL	SEAT MATERIAL	SEAL MATERIAL	BEARING MATERIAL	SHAFT PACKING	ACTUATOR TYPE	SEAL PERFORMANCE	TESTING	STD OPTIONS
03=3"	15=150	01=WAFER, CS	1=17-4PH	B=SST	1=SOLID, SST	C=CARBON	G=GRAPHITE	B=BARE SHAFT	6=CLASS VI	S=STD SHELL & SEAT	1P=ENP DISC/CLAMP RING
04=4"	30=300	02=WAFER, SST	3=INCONEL	C=INCONEL	3=MONEL/ GRAPH	N=NITRONIC 60	T=TEFLON	C=GEAR & CHAINWHEEL	B=ZERO LEAKAGE		G5=LIVE LOADED PACKING
06=6"	60=600	03=LUG, CS	4=K MONEL	D=MONEL	4=ALLOY 20/ GRAPH			E=ELECTRIC	5=CLASS V IN PREFERRED DIRECTION (DEFAULT FOR SOLID SST SEAL)		G4=PURGE PORT & LANTERN RING
08=8"		04=LUG, SST	5=316 SST	E=ALLOY 20	5=SST/ GRAPHITE			G=GEAR			C1=STD OXYGEN CLEAN & WRAP
10=10"		S1=WAFER, CS/SST S2=LUG, CS/SST		S=STELLITE	K=SST/ KLINGER			H=HYDRAULIC			T=STEAM TRACED SHAFT
12=12"		Y1= WAFER CRYO, SST Y2=LUG CRYO, SST						P=PNEUMATIC			J=WELD-ON STEAM JACKET (WAFER STYLE BODY ONLY)
14=14"		97=SPECIAL WAFER									K=BOLT-ON STEAM JACKET (WAFER STYLE BODY ONLY)
16=16"		98=SPECIAL LUG									N1=NACE COMPLIANT
18=18"											
20=20"											
24=24"											
30=30"											
36=36"											
42=42"											
48=48"											
SPECIAL OPTION			x	x	x	x	x	S	S	T	99=SPECIAL CONSTRUCTION

Example:

6" Class 150 carbon steel lug with manual gear actuator = 0615031B5CGG6S

Ordering Information

Product Model Number Configuration Flanged (ISO & B16.10) Valves

VALVE SIZE	RATING CLASS	BODY STYLE & BODY/DISC MATERIAL	SHAFT MATERIAL	SEAT MATERIAL	SEAL MATERIAL	BEARING MATERIAL	SHAFT PACKING	ACTUATOR TYPE	SEAL PERFORMANCE	TESTING	STD OPTIONS
03=3"	15=150	D1=FLGD, B16.10 CS	1=17-4PH	5=SST	1=SOLID, SST	C=CARBON	G=GRAPHITE	B=BARE SHAFT	B=ZERO LEAKAGE (DEFAULT FOR SST/GRAPHITE SEAL)	S=STD SHELL & SEAT	1P=ENG DISC/CLAMP RING
04=4"	30=300	D2=FLGD, B16.10 SST	3=INCONEL	C=INCONEL	3=MONEL/GRAPH	N=NITRONIC 60	T=TEFLON	C=GEAR & CHAINWHEEL	5=CLASS V IN PREFERRED DIRECTION (DEFAULT FOR SOLID SST SEAL)		G5=LIVE LOADED PACKING
06=6"	60=600	D3=FLGD, ISO CS	4=K MONEL	D=MONEL	4=ALLOY 20/GRAPH			E=ELECTRIC			G4=PURGE PORT & LANTERN RING
08=8"		D4=FLGD, ISO SST	5=316 SST	E=ALLOY 20	5=SST/GRAPHITE			G=GEAR			C1=STD OXYGEN CLEAN & WRAP
10=10"		D5=FLGD, B16.10		S=STELLITE				H=HYDRAULIC			T=STEAM TRACED SHAFT
12=12"		D6=FLGD, ISO CS/SST						P=PNEUMATIC			J=WELD-ON STEAM JACKET
14=14"		D7=FLGD, B16.10 LCB/SST									K=BOLT-ON STEAM JACKET
16=16"		D8=FLGD, ISO LCB/SST									N1=NACE COMPLIANT
18=18"		Y4=FLGD, ISO CRYOGENIC SST									
20=20"		Y5=FLGD, B16.10 CRYOGENIC SST									
24=24"											
30=30"											
36=36"											
42=42"											
48=48"											
SPECIAL OPTION			x	x	x	x	x	S	S	T	99=SPECIAL CONSTRUCTION

Example:

12" Class 150 carbon steel double flanged ISO valve with manual gear actuator = 1215D355CGG6S.

Global Presence

Weir Valves & Controls USA Inc. has established a network of manufacturing locations, trading hubs, sales representatives and stocking distributors for its TRICENTRIC® brand of triple offset butterfly valves. Our sales channel partners are committed to finding solutions to tough process challenges in the industry today. For more information, visit www.weirpowerindustrial.com or email sales@weirvalveusa.com

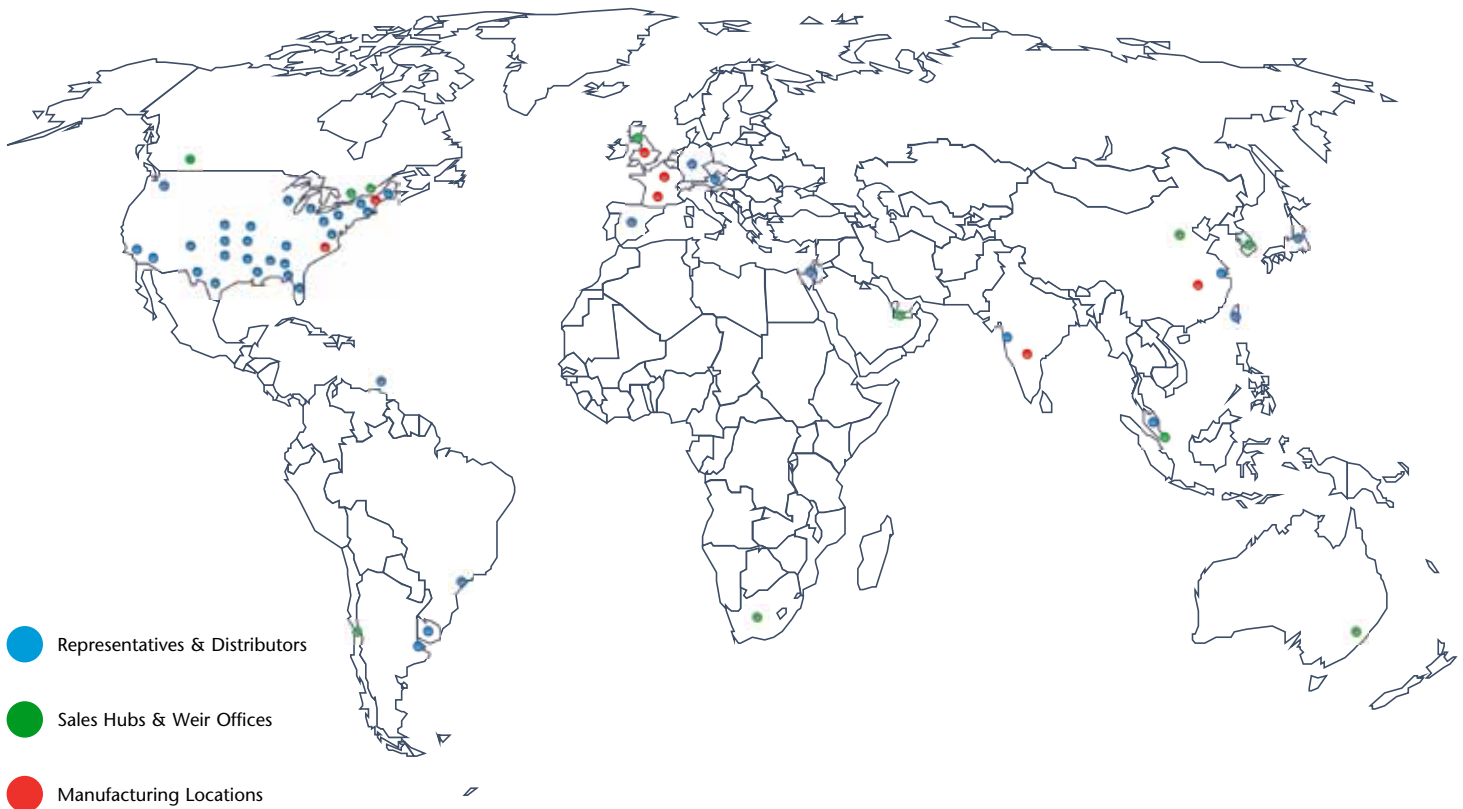

Sales Contacts

China - Beijing
Tel: +86 10 8528 8315
Email: china@weirpowerindustrial.com

France – Vendin le Vieil
Tel: + 33 321 795 450
Email: sales-fr.tricentric@weirgroup.com

India - Mumbai
Tel: +91 836 2333930
Email: sales.weirbdk@weirgroup.com

Korea
Tel: +82 31 493 7979
Email: weirhops@chol.com

Middle East - UAE
Tel: +971 6 598 1300
Email: wvcme@weirgroup.com

Pacific Rim – Singapore
Tel: +65 6302 0880
Email: pacificrimenq@weirgroup.com

South Africa
Tel: +27 11 929 2929
Email: jimmy.georgiou@weirpowerindustrial.com

United Kingdom – Elland
Tel: +44 1422 282 231
Email: info@weirpowerindustrial.com

United States & Canada
Tel: +1 978 744 5690
Email: sales@weirvalveusa.com

**ALLEN STEAM
TURBINES™**

Single & Multi-stage Steam Turbines

AMERICAN HYDRO™
High Performance Hydro Products
& Services

ATWOOD & MORRILL™
Engineered Isolation & Check Valves

BATLEY VALVE®
High Performance Butterfly Valves

BDK™
Industrial Valves

BLAKEBOROUGH®
Control & Severe Service Valves

HOPKINSONS®
Parallel Slide Gate & Globe Valves

MAC VALVE®
Ball & Rotary Gate Valves

ROTO-JET®
High Pressure Pitot Tube Pumps

SARASIN-RSBD™
Pressure Safety Devices

SEBIM™
Nuclear Valves

TRICENTRIC®
Triple Offset Butterfly Valves

WEMCO®
Pumps & Systems

**WEIR POWER
& INDUSTRIAL
SERVICES™**

Plus over 150 years service in:

WEIR VALVES & PUMPS
MATHER & PLATT PUMPS
HARLAND PUMPS & TURBINES
DRYSDALE PUMPS
and many others...

A&M 120111 R1

* Survey conducted by Satmetrix Systems Inc. in 2010 and 2011. Copyright © 2011, Weir Valves & Controls USA Inc. All rights reserved. ALLEN STEAM TURBINES is a trademark of Weir Engineering Services Ltd; AMERICAN HYDRO is a trademark of American Hydro Corporation; ATWOOD & MORRILL is a trademark of Weir Valves & Controls USA, Inc; TRICENTRIC is a registered trademark of Weir Valves & Controls USA, Inc; BDK is a trademark of Weir India Pvt Limited; BATLEY VALVE, BLAKEBOROUGH, HOPKINSONS, X-STREAM and MAC VALVE are registered trademarks of Weir Valves & Controls UK Ltd; SARASIN-RSBD, SEBIM, STARFLOW and STARVALVE are trademarks of Weir Power & Industrial France SAS; ROTO-JET and TORQUE-FLOW are registered trademarks of Envirotech Pumpsystems, Inc.; HYDROGRITTER is a trademark of Envirotech Pumpsystems, Inc.; WEIR is a registered trademark of Weir Engineering Services Ltd. All other trademarks mentioned in this publication are not trademarks belonging to Weir Valves & Controls USA, Inc. or any other company forming part of The Weir Group PLC. WEMCO and HIDROSTAL are registered trademarks used under licence by companies forming part of The Weir Group PLC.

Weir Valves & Controls USA Inc.

29 Old Right Road
Ipswich, MA 01938
USA

Tel: +1 978 744 5690
Email: sales@weirvalveusa.com
Web: www.weirpowerindustrial.com

Excellent
Power & Industrial
Solutions

