

# XOMOX<sup>®</sup>

THE FIRST SLEEVED PLUG  
VALVE ABLE TO PASS  
FOUR (4) THERMAL CYCLES  
WITH ZERO PACKING ADJUSTMENTS

brands you trust.

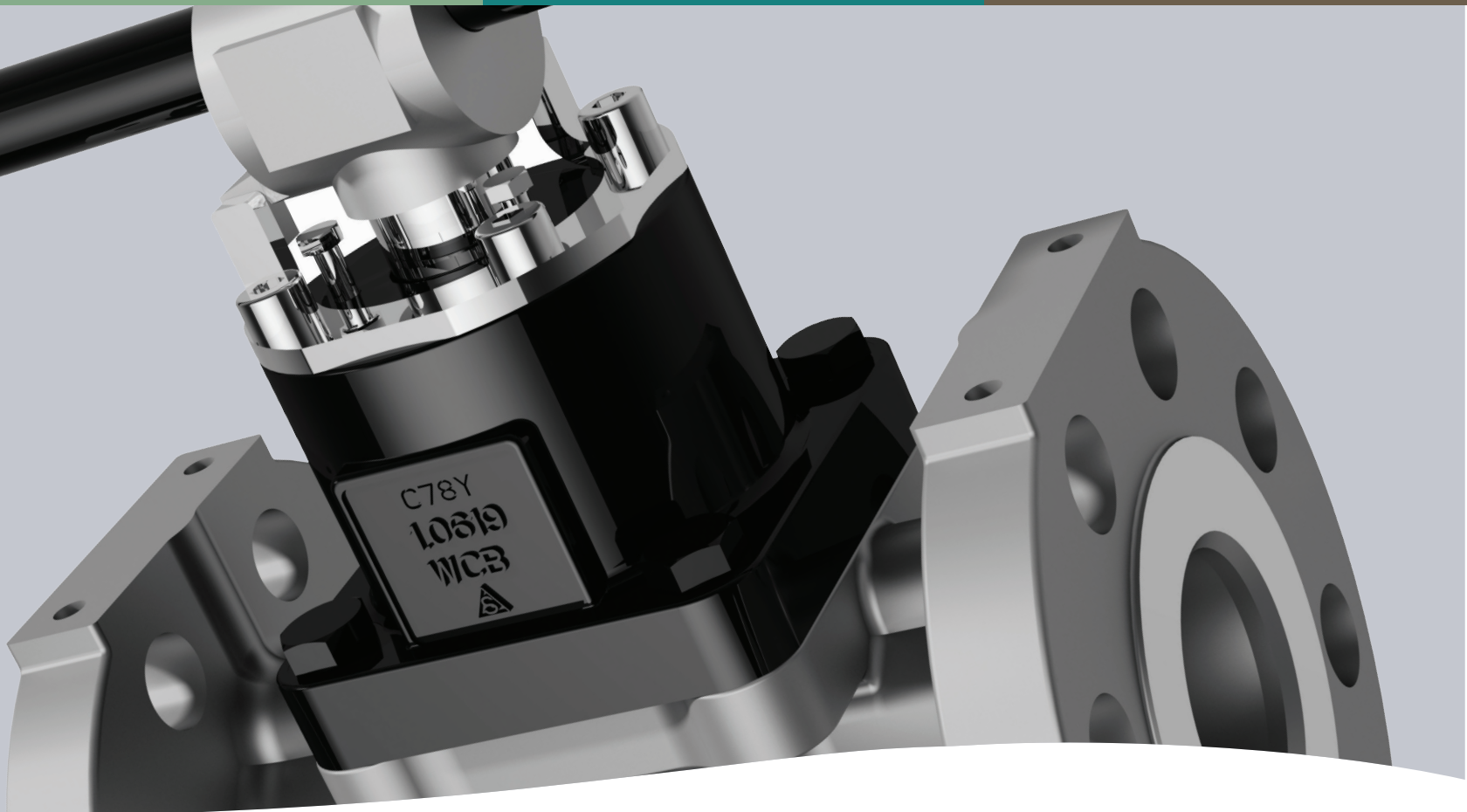

## XOMOX<sup>®</sup> XP3 Low Emission Sleeved Plug Valves



Crane ChemPharma & Energy

[www.cranecpe.com](http://www.cranecpe.com)

## ISO 15848 Standard Introduction



International  
Organization for  
Standardization

INTERNATIONAL .....ISO  
STANDARD ..... 15848-1

ISO 15848-1 is an International standard for fugitive emissions issued by the ISO Organization. It contains both dynamic life cycles and thermal cycles and is considered one of the most demanding fugitive emission standards for soft seated valves. This standard contains different levels of acceptance based on the number of thermal and mechanical cycles, temperature, and number of adjustments. The objective of ISO 15848-1 is to enable classification of performance in different designs and constructions of valves to reduce fugitive emissions.

### Example Description Tables

**ISO 15848 – 1 BH CO3 392°F – SSA 0** (200°C)

Part Composition		Number of Adjustments
<b>Part 1: Design</b> <ul style="list-style-type: none"> <li>System of classification and procedures of qualification for the tests of the valve type</li> </ul>	Part 2: Industrial (Production) <ul style="list-style-type: none"> <li>Acceptance tests in production of the valves</li> <li>Non-destructive</li> </ul>	<b>0 / 1 / 2 / 3</b>

Temperature Classes				
(T-196°C)	(T-40°C)	(T RT)	(T200°C)	(T400°C)
-320°F	-40°F	Room temperature, °F	<b>392°F</b>	752°F
-196°C	-40°C	Room temperature, °C	<b>200°C</b>	400°C

Class	Measured Leak Rate <sup>a</sup> mg s <sup>-1</sup> m <sup>-1</sup>	Remarks
A <sup>b</sup>	≤ 10 <sup>-6</sup>	Typically achieved with bellow seals or and equivalent stem (shaft) sealing system for quarter turn valves
B	≤ 10 <sup>-4</sup>	<b>Typically achieved with PTFE based packings or elastomeric seals</b>
C	≤ 10 <sup>-2</sup>	Typically achieved with flexible graphite based packings

<sup>a</sup> Expressed in mg s<sup>-1</sup> m<sup>-1</sup> measured with total leakage method  
<sup>b</sup> Class A can be measured only with helium using the vacuum method

Classification	Minimum number of mechanical cycles
CO1	500 cycles, with two thermal cycles (except for RT)
CO2	1,500 cycles, with three thermal cycles
<b>CO3</b>	<b>2,500 cycles, with four thermal cycles</b>

Test Fluid	Class
H - Helium	<b>AH, BH, CH</b>
M - Methane	BM, CM

When the test fluid is **helium**, classes are identified as **AH, BH and CH**.  
 When the test fluid is **methane**, classes are identified as **BM and CM**.

Manufacturing valves will be subjected to the ISO 15848-2 test as described in the norm. This is a non-destructive test that intends to address the performance of the valves (Please refer to ISO 15848 norm).

## XOMOX® XP3 Low Emission Sleeved Plug Valves (SPV)

The first sleeved plug valves capable of passing four (4) thermal cycles with ZERO packing adjustments.

### Key Features & Benefits

- 1 Innovative stem seal design permits best in class FUGITIVE EMISSIONS CONTROL (ISO 15848-1 BH CO3 392°F or 200°C SSA 0).
- 2 Live-loaded design optimizes sealing performance (self-adjusted) and extended service life with ZERO PACKING ADJUSTMENTS through thermal cycling.
- 3 MAINTENANCE and CAVITY FREE: No costly lubrication, no sticking, and no contamination of process media.

### XOMOX® XP3 LIVE-LOADED STEM CARTRIDGE SEAL

The new XOMOX® XP3 Soft Seated Sleeved Plug Valve incorporates a Live-loaded Stem Cartridge which enables to meet the most stringent emissions standards in the industry.

### Options:

- Options for different packing materials to suit different temperatures and applications (392°F/200°C or 500°F/260°C); PTFE & graphite packing.
- All current XOMOX® sleeve material options are available.
- XP4D design; Option for an additional manual 4D stem seal which provides the same emissions performance as the XP3 configuration.
- XP3 and XP4D are API 641 Class B and E approved.
- Firetest according to API 607 7<sup>th</sup> edition.

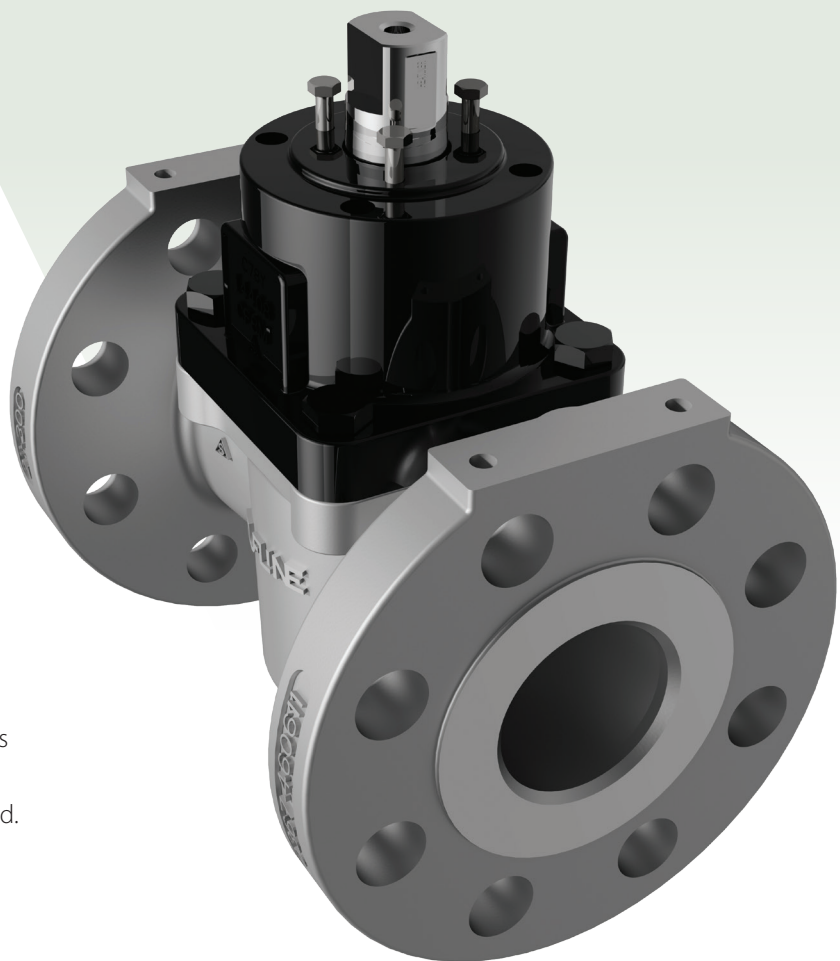

## XOMOX® XP3 Low Emission SPV Features and Benefits

XP3 Sleeved Plug Valves are the first valves capable to pass all four thermal cycles without any packing adjustments, while meeting the ISO 15848-1 standard at the BH CO3 200°C/392°F SSA 0. The new XOMOX® valve top seal technology is able to perform in its entire temperature range even under thermal cycle conditions. This is achieved by the patented Live-loaded stem cartridge.

The XP3 design incorporates the same features and benefits of the standard XOMOX® Sleeve Plug Valve by being maintenance and cavity-free. These valves require no costly lubrication and prevent accumulation or contamination of process media, reducing maintenance costs and the cost of ownership over time.

### 1 Primary Seal to Atmosphere

The XP3 utilizes the same proven sleeve and body design XOMOX® is known for. Its 360° port lips and high pressure ribs inside the valve body ensure tight in-line seal & primary seal to atmosphere. Plug remains adjustable if necessary.

### 3 Tertiary Seal to Atmosphere

**NEW** live-loaded stem cartridge delivers world class low E performance in a quarter-turn soft-seated plug valve.

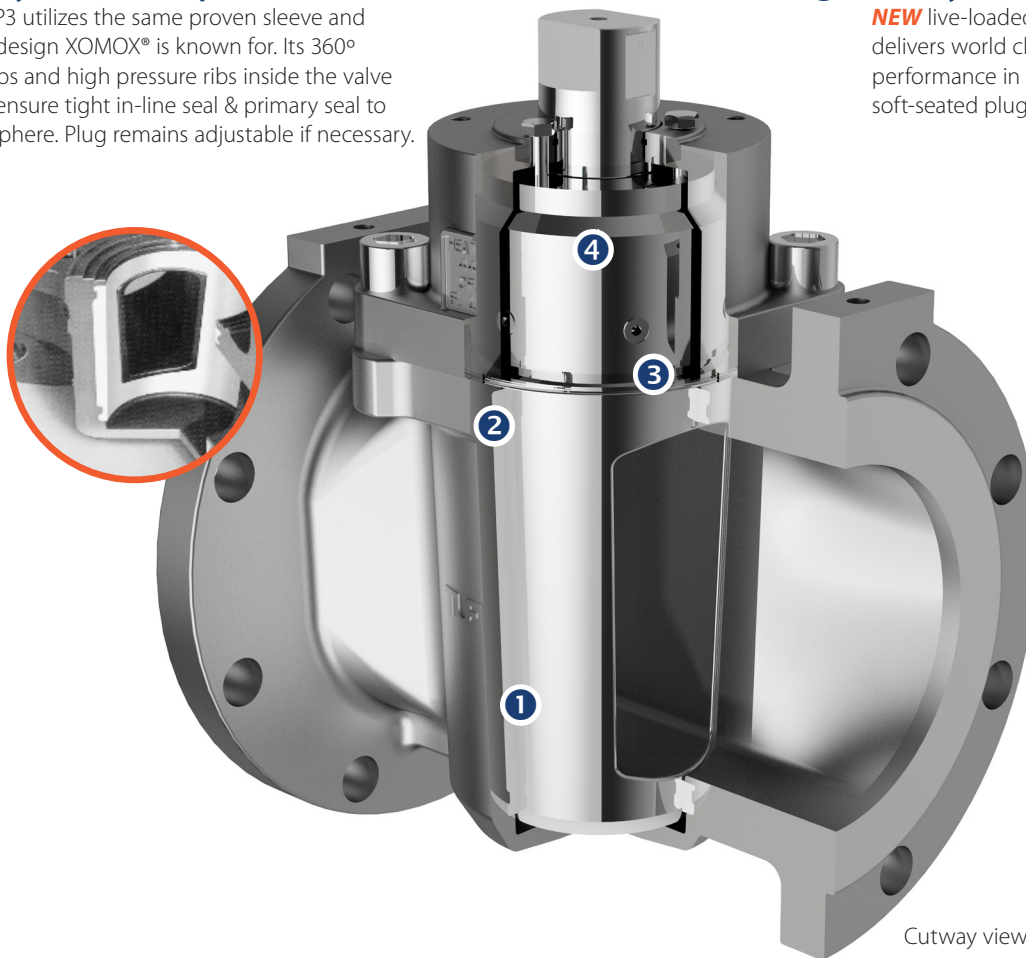

Cutway view on XP3

### 2 Secondary Seal to Atmosphere

Enabled by the same wedge ring and plastic diaphragm design that is in place on our existing product, ensuring another layer of protection to stem seal and body cover joint.

### 4 Packing Options

Stem packing can be changed depending on operating conditions. Various packing options are available.

## XOMOX® XP3 Low Emission SPV Features and Benefits

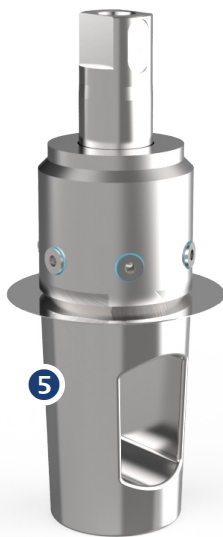

- 5 Patented live-loaded stem cartridge design**  
Optimizes sealing integrity to atmosphere and extended service life.

### XP3 maintains all design features of current XOMOX® SPV

- **Re-inforced** body cover joint gasket for emissions-proof valves.
- **360° port lips** on body prevent cold flow and deformation of the sleeve, eliminating the chances that the sleeve will rotate during thermal cycling.
- **Plug vent hole** options depending on different service conditions.
- **Actuator mounting** capabilities per ISO 5211.
- **Flange pad design** remains available per the standard configuration.
- All **sleeve materials** are available.
- **Current material** selection on body and plug are available.

## MEETING BEST IN CLASS FUGITIVE EMISSIONS STANDARDS

### ISO 15848-1 BH CO3 200°C/392°F SSA 0

- Tightness class BH (<0-4 mg/(s x m))
- Endurance class CO3
- Temperature class RT to 200°C/392°F
- Adjustments: SSA 0 (zero packing adjustments)



International  
Organization for  
Standardization

**Option:**  
**API 641 Class B and E**  
**(200°C/392°F) (260°C/ 500°F)**



AMERICAN PETROLEUM INSTITUTE

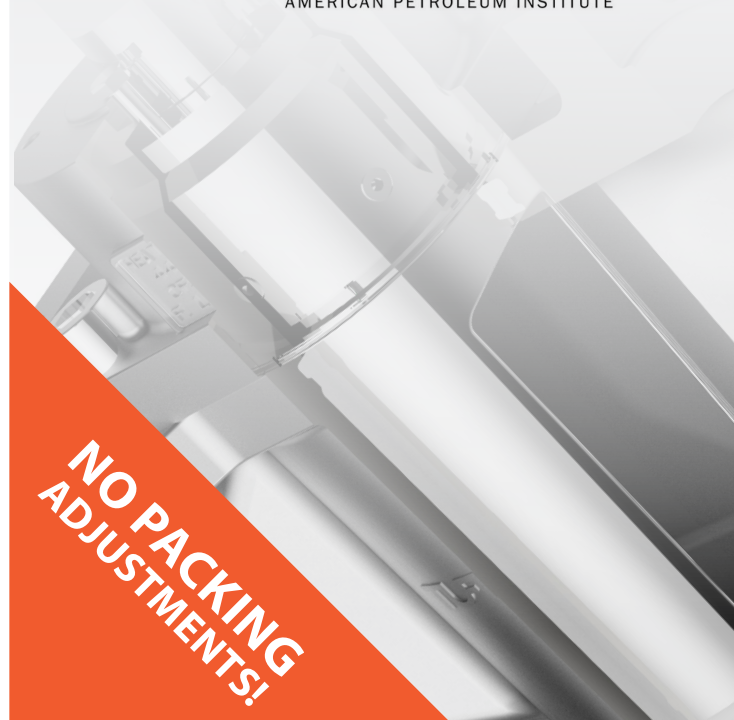

# XOMOX® XP3 Low Emission SPV Properties & Characteristics

## XP3 Break Torque - Class 150 and 300 [in\*lbs]

Size	PTFE/PTFEX		%R-PTFE Sleeve		PTFEXC/XeniTh Sleeve		UHMWPE/PFA Sleeve	
	Std	Built Dry	Std	Built Dry	Std	Built Dry	Std	Built Dry
½" & ¾"	163	244	204	305	214	326	326	478
1"	458	692	580	865	621	936	916	1384
1 ½"	916	1384	1150	1730	1242	1863	1842	2758
2"	1262	1893	1578	2372	1710	2565	2534	3797
3"	1384	2066	1730	2585	1863	2799	2758	4143
4"	2758	4143	3450	5181	3725	5588	5517	8285
6"	5751	8621	7186	10779	7766	11644	11502	17252
8"	8967	13456	11217	16815	12112	18168	17944	26912
10"	16560	24845	20703	31054	22352	33538	33120	49681
12"	24153	36225	30189	45284	32601	48907	48296	72450

If any additional information is required, please contact your sales representative or customer service.

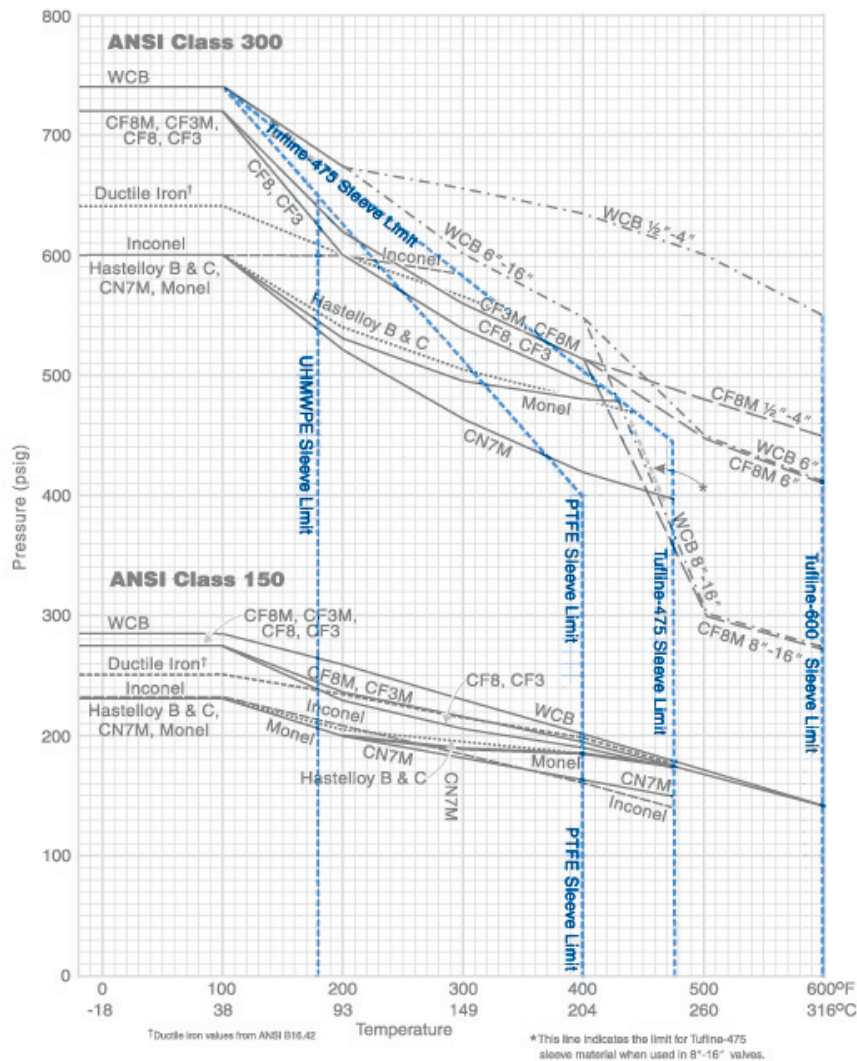

# XOMOX® XP3 Low Emission SPV Dimensional Data

## Bare Stem Operated

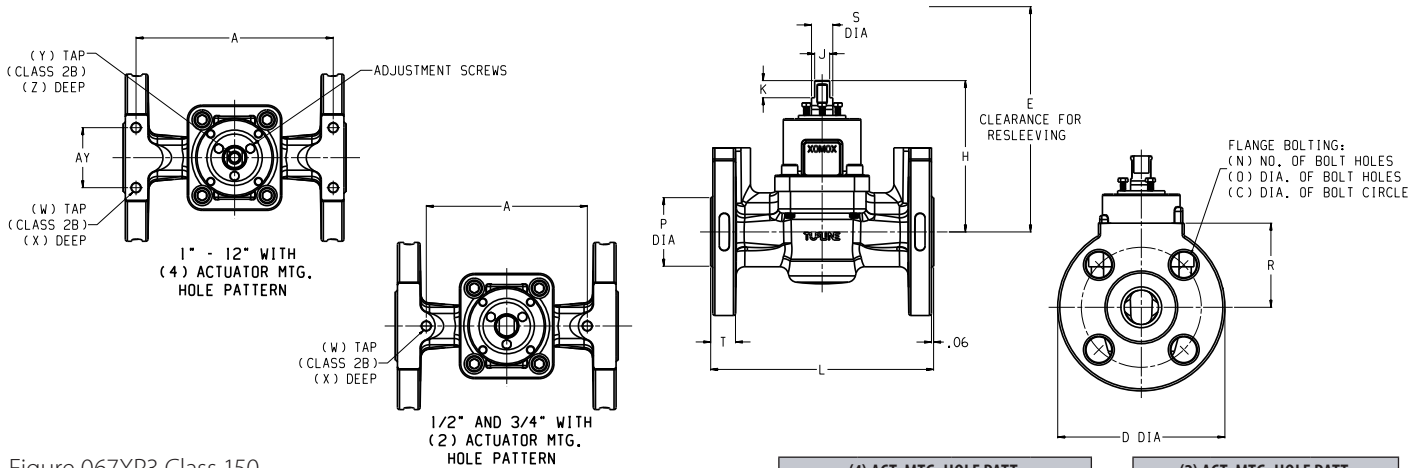

Figure 067XP3 Class 150

SIZE	L	D	T	R	N	O	C	W
1/2"	4.25	3.50	.38	1.75	4	.63	2.38	3.1
3/4"	4.63	3.88	.41	1.94	4	.63	2.75	3.6
1"	5.00	4.25	.44	2.13	4	.63	3.13	7.2
1-1/2"	6.50	5.00	.56	2.50	4	.63	3.88	14
2"	7.00	6.00	.63	3.00	4	.75	4.75	21
3"	8.00	7.50	.75	3.75	4	.75	6.00	33
4"	9.00	9.00	.94	4.63	8	.75	7.50	57
6"	10.50	11.00	1.00	5.50	8	.88	9.50	98
8"	11.50	13.50	1.13	6.75	8*	.88	11.75	180
10"	13.00	16.00	1.19	8.00	12*	1.00	14.25	268
12"	14.00	19.00	1.25	9.50	12*	1.00	17.00	366

(4) ACT. MTG. HOLE PATT.			
A	AY	W	X
----	----	-----	---
3.625	5/16 - 18	.47	.38
3.750	5/16 - 18	.47	.47
6.313	2.250	5/16 - 18	.47
7.125	3.500	3/8 - 16	.56
8.000	4.000	7/16 - 14	.63
9.438	4.000	7/16 - 14	.63
10.188	6.000	1/2 - 13	.63
11.562	6.000	1/2 - 13	.63
12.532	6.000	1/2 - 13	.63

(2) ACT. MTG. HOLE PATT.		
A	W	X
3.625	5/16 - 18	.47
3.750	5/16 - 18	.47
----	-----	---
----	-----	---
----	-----	---
----	-----	---
----	-----	---
----	-----	---
----	-----	---
----	-----	---
----	-----	---
----	-----	---

Figure 0367XP3 Class 300

SIZE	L	D	T	R	N	O	C	W
1/2"	5.50	3.75	.56	1.88	4	.63	2.63	6.6
3/4"	6.00	4.63	.63	2.31	4	.75	3.25	9.9
1"	6.50	4.88	.69	2.44	4	.75	3.50	12
1-1/2"	7.50	6.13	.81	3.06	4	.88	4.50	22
2"	8.50	6.50	.88	3.25	8	.75	5.00	29
3"	11.13	8.25	1.13	4.13	8	.88	6.63	40
4"	12.00	10.00	1.25	5.13	8	.88	7.88	84
6"	15.88	12.50	1.44	6.25	12	.88	10.63	170
8"	16.50	15.00	1.63	7.50	12	1.00	13.00	275
10"	18.00	17.50	1.88	8.75	16	1.13	15.25	407
12"	19.75	20.50	2.00	10.25	16	1.25	17.75	556

(4) ACT. MTG. HOLE PATT.			
A	AY	W	X
----	----	-----	---
5.570	1.750	5/16 - 18	.38
6.625	1.150	5/16 - 18	.47
7.563	2.250	5/16 - 18	.47
9.938	3.500	3/8 - 16	.56
10.688	4.000	7/16 - 14	.63
14.000	4.000	7/16 - 14	.63
14.625	6.000	1/2 - 13	.63
15.688	6.000	1/2 - 13	.63
17.375	6.000	1/2 - 13	.63

(2) ACT. MTG. HOLE PATT.		
A	W	X
4.375	5/16 - 18	.47
3.750	5/16 - 18	.47
----	-----	---
----	-----	---
----	-----	---
----	-----	---
----	-----	---
----	-----	---
----	-----	---
----	-----	---
----	-----	---
----	-----	---

\*see note 1

Figure 067XP3 (Class 150) & 0367XP3 (Class 300)

SIZE	H	S	J	K	P	E	Y	Z
1/2"	4.591	.537	.437	.500	1.38	8.68	1/4 - 20	.91
3/4"	4.591	.537	.437	.500	1.69	8.68	1/4 - 20	.91
1"	4.433	.620	.437	.500	2.00	8.93	1/4 - 20	.91
1-1/2"	5.456	.848	.563	.530	2.88	10.43	5/16 - 18	.91
2"	6.067	1.102	.755	.748	3.63	11.63	5/16 - 18	.91
3"	6.598	1.102	.755	.748	3.63	11.63	5/16 - 18	.91
4"	8.054	1.260	.880	1.000	6.19	24.83	5/16 - 18	.91
6"	9.590	2.008	1.398	1.000	10.63	30.47	5/16 - 18	.91
8"	11.795	2.008	1.398	1.000	10.63	30.47	5/16 - 18	.91
10"	13.291	2.500	1.673	1.000	12.75	31.47	1/2 - 13	.91
12"	14.315	2.992	1.968	1.000	15.00	37.53	1/2 - 13	.91

NOTES

- 2 top holes in the flanges of 8" Fig. 067XP3 are tapped 3/4 - 10unc - 2b threads  
2 top holes in the flanges of 10", 12" Fig. 067XP3 are tapped for 7/8 - 9unc - 2b
- Weight of valve in pounds. All weights are estimated

## XOMOX<sup>®</sup> XP3 Low Emission SPV Dimensional Data

### Wrench Operated

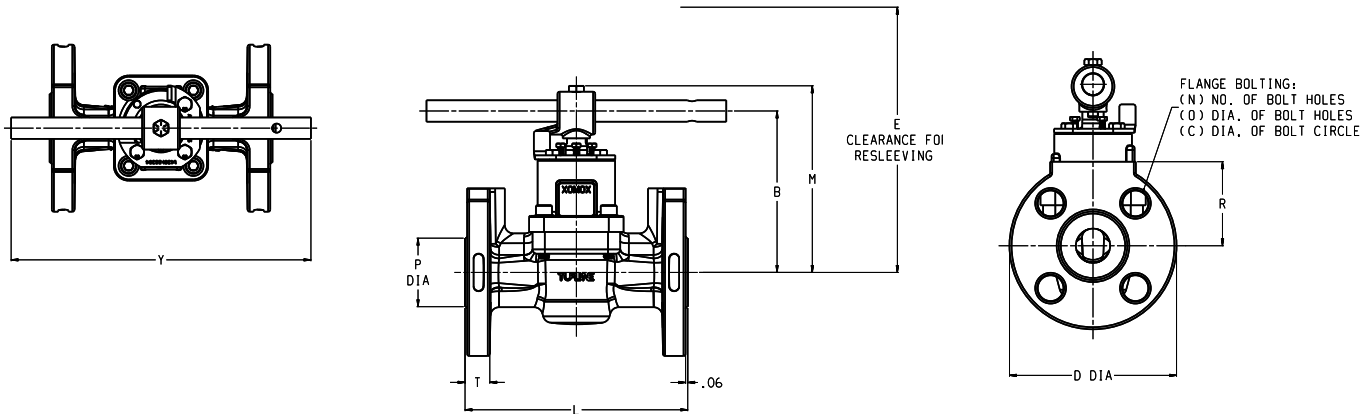

Figure 067XP3 Class 150

SIZE	L	D	T	P	R	N	O	C	E	M	B	Y	W
1/2"	4.25	3.50	.38	1.38	1.75	4	.63	2.38	8.68	5.61	4.89	8.75	5.1
3/4"	4.63	3.88	.41	1.69	1.94	4	.63	2.75	8.68	5.61	4.89	8.75	5.6
1"	5.00	4.25	.44	2.00	2.13	4	.63	3.13	8.93	5.45	4.73	8.75	9.2
1-1/2"	6.50	5.00	.56	2.88	2.50	4	.63	3.88	10.43	6.62	5.79	12.50	17
2"	7.00	6.00	.63	3.63	3.00	4	.75	4.75	11.63	7.44	6.61	18.00	24
3"	8.00	7.50	.75	5.00	3.75	4	.75	6.00	12.63	7.96	7.13	24.00	37
4"	9.00	9.00	.94	6.19	4.63	8	.75	7.50	24.83	9.76	8.68	30.00	65

Figure 0367XP3 Class 300

SIZE	L	D	T	P	R	N	O	C	E	M	B	Y	W
1/2"	5.50	3.75	.56	1.38	1.88	4	.63	2.63	8.68	5.61	4.89	8.75	8.6
3/4"	6.00	4.63	.63	1.69	2.31	4	.75	3.25	8.68	5.61	4.89	8.75	12
1"	6.50	4.88	.69	2.00	2.44	4	.75	3.50	8.93	5.45	4.73	8.75	14
1-1/2"	7.50	6.13	.81	2.88	3.06	4	.88	4.50	10.43	6.62	5.79	12.50	25
2"	8.50	6.50	.88	3.63	3.25	8	.88	5.00	11.63	7.44	6.61	18.00	32
3"	11.13	8.25	1.13	5.00	4.13	8	.88	6.63	12.63	7.96	7.13	24.00	44
4"	12.00	10.00	1.25	6.19	5.13	8	.88	7.88	24.83	9.76	8.68	30.00	92

All dimensions in inches. Weight of valve in pounds. All weights are estimated.



# XOMOX® XP3 Low Emission SPV Dimensional Data

## Gear Operated

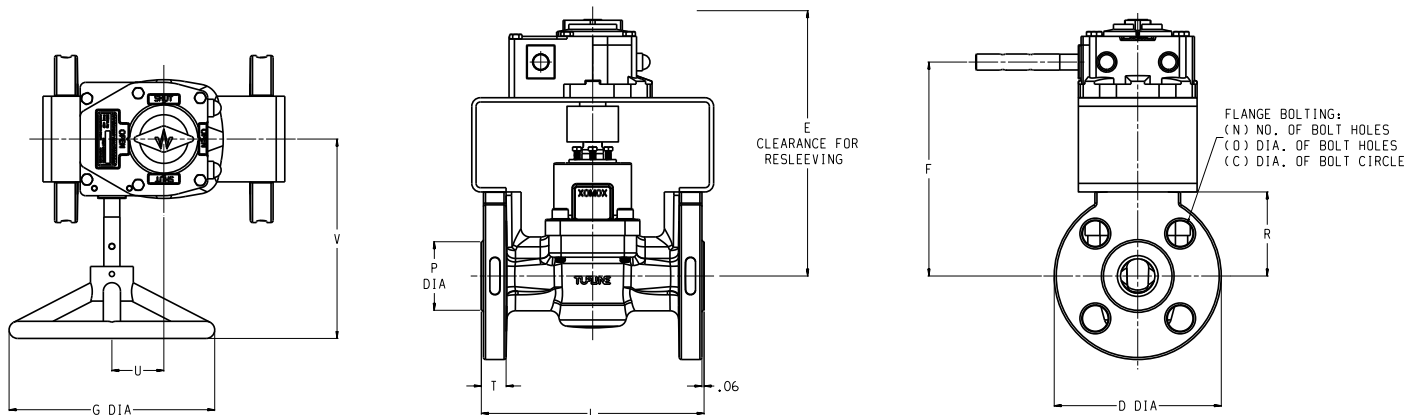

Figure 067XP3 Class 150

SIZE	L	D	T	P	R	N	O	C	E	F	G	U	V	W
3"	8.00	7.50	.75	5.00	3.75	4	.75	6.00	12.63	10.38	12.00	2.05	7.77	56
4"	9.00	9.00	.94	6.19	4.63	8	.75	7.50	24.83	11.57	12.00	2.05	7.77	82
6"	10.50	11.00	1.00	8.50	5.50	8	.88	9.50	27.25	13.78	18.00	2.63	10.30	142
8"	11.50	13.50	1.13	10.63	6.75	8*	.88	11.75	30.47	16.03	18.00	3.52	10.96	250
10"	13.00	16.00	1.19	12.75	8.00	12*	1.00	14.25	31.47	17.78	24.00	4.84	14.26	372
12"	14.00	19.00	1.25	15.00	9.50	12*	1.00	17.00	37.53	18.78	30.00	4.84	15.76	480

Figure 0367XP3 Class 300

SIZE	L	D	T	P	R	N	O	C	E	F	G	U	V	W
3"	11.13	8.25	1.13	5.00	4.13	8	.88	6.63	12.63	10.38	12.00	2.05	7.77	64
4"	12.00	10.00	1.25	6.19	5.13	8	.88	7.88	24.83	11.57	12.00	2.05	7.77	110
6"	15.88	12.50	1.44	8.50	6.25	12	.88	10.63	27.25	13.78	18.00	2.53	10.30	218
8"	16.50	15.00	1.63	10.63	7.50	12	1.00	13.00	30.47	16.03	18.00	3.53	10.96	349
10"	18.00	17.50	1.88	12.75	8.75	16	1.13	15.25	31.47	17.78	24.00	4.84	14.26	515
12"	19.75	20.50	2.00	15.00	10.25	16	1.25	17.75	37.53	18.78	30.00	4.84	15.76	674

\*See note 1

NOTES:

- 2 top holes in the flanges of 8" Fig. 067XP3 are tapped 3/4-10unc-2B threads  
Top holes in the flanges of 10", 12" Fig. 067XP3 are tapped for 7/8-9unc-2B threads
- All dimensions in inches. Weight of valve in pounds. All weights are estimated
- All operator related dimensions are assuming gears and handwheels are sized for valves with PTFE sleeves
- For valves where the operating force exceeds the recommendations of MSS SP 91 - (Maximum operating force between hip and shoulder level is 150lbs). The dimensional table show lever lengths for standard PTFE builds, other operating conditions and/or builds should be reviewed for lever lengths or fitment of a gear operator.

## XOMOX® XP3 Full Port Low Emission SPV

### XOMOX® FULL PORT DESIGN

With the full-area round port there is no diminished or constricted flow.

Ideal wherever low pressure-drop and high-flow efficiency are important.

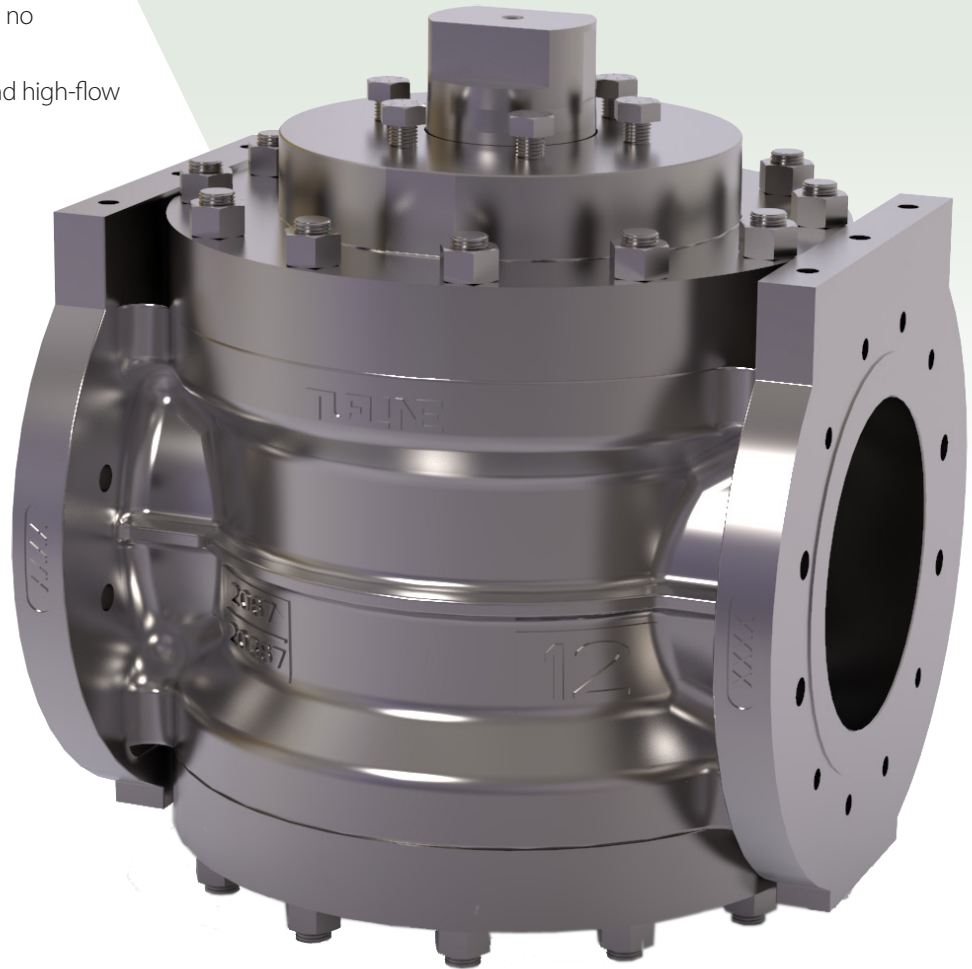

### Reference of Available Configurations and Figure numbers

Size (inch)	ASME Class	Figure Number	Flanged Ends
2" - 12"	150	2067XP3	X
2" - 12"	300	20367XP3	X

# XOMOX® XP3 Full Port Low Emission SPV Dimensional Data

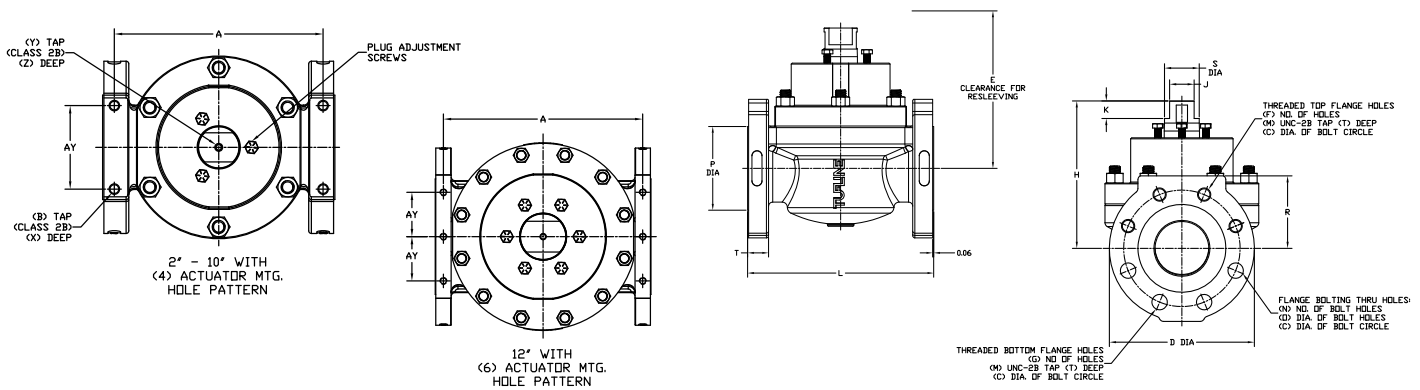

Figure 2067XP3

SIZE	L	D	T	R	N	O	C	F	G	M	W
2"	8.50	6.50	.94	3.16	4	.75	4.75	—	—	—	54
3"	11.13	8.25	1.25	4.13	2	.75	6.00	2	0	5/8–11	124
4"	12.00	10.00	1.43	5.00	6	.75	7.50	2	0	5/8–11	189
6"	15.88	12.50	1.50	6.44	0	—	9.50	4	4	3/4–10	404
8"	19.75	15.00	1.73	7.56	4	.88	11.75	2	2	3/4–10	823
10"	22.38	17.50	2.03	8.84	6	1.00	14.25	4	2	7/8–9	1344
12"	28.00	23.00	2.06	11.56	4	1.00	17.00	4	4	7/8–9	2612

Figure 20367XP3

SIZE	L	D	T	R	N	O	C	F	G	M	W
2"	8.50	6.50	.94	3.16	8	.75	5.00	—	—	—	53
3"	11.13	8.25	1.25	4.13	4	.88	6.63	4	0	3/4–10	122
4"	12.00	10.00	1.43	5.00	6	.88	7.88	2	0	3/4–10	188
6"	15.88	12.50	1.50	6.44	4	.88	10.63	4	4	3/4–10	402
8"	19.75	15.00	1.73	7.56	6	1.00	13.00	4	2	7/8–9	819
10"	22.38	17.50	2.03	8.84	8	1.13	15.25	6	2	1–8	1338
12"	28.00	23.00	2.06	11.56	8	1.25	17.75	4	4	1–1/4–8*	2600

\* UN-8 THREAD

Figure 2067XP3 and 20367XP3

SIZE	H	S	J	K	P	E	Y	Z	A	AY	B	X
2"	7.414	1.258	.874	.984	3.63	11.38	5/16–18	.88	7.50	4.00	7/16–14	.69
3"	8.388	2.008	1.398	1.000	5.00	13.50	5/16–18	.88	10.00	4.00	1/2–13	.63
4"	8.956	2.500	1.673	1.000	6.19	15.38	1/2–13	.75	10.69	4.00	1/2–13	.63
6"	10.575	2.992	1.969	1.000	8.50	19.25	1/2–13	.75	14.38	5.50	5/8–11	1.00
8"	14.789	3.937	2.000	1.575	10.63	26.00	1/2–13	.75	18.06	8.00	3/4–10	1.13
10"	16.897	6.000	4.000	2.000	12.75	30.38	3/4–10	1.00	20.44	8.00	3/4–10	1.13
12"	18.221	6.000	4.000	2.000	15.00	24.25	3/4–10	1.00	25.88	5.75	7/8–9	1.31

NOTES:

1. Weight of valves in pounds. All weights are estimate.
2. 12" 2067XP3 / 20367XP3 uses bottom cover design.

## XOMOX® XP3 Low Emission SPV Applications

### APPLICATIONS

#### Chlor-Akali

- Chlorine & Derivatives
- Caustic Soda & Derivatives

#### Olefins

- Ethylene & Derivatives
- Ethylene Oxide & Derivatives
- Butadiene & Derivatives
- Propylene & Derivatives

#### Aromatics

- Styrene & Derivatives
- Benzene & Derivatives
- Toluene & Derivatives
- Xylene & Derivatives



### XOMOX® XP3 - PERFORMANCE CHART

● Well Suited    ● Appropriate Application    ● Limited Application

FUNCTION	ON / Off	●
	Throttling	●
	Diversion	●
MEDIA TYPES	Clean Liquids & Gases	●
	Dirty Liquids & Gases	●
	Corrosive Liquids & Gases	●
	Hazardous Liquids & Gases	●
	Viscous Liquids	●
	Scaling Liquids & Slurries	●
	Abrasive Slurries	●
	Fibrous Slurries	●
	High Pressure Steam (>150 lbs.)	●
	Low Pressure Steam (<150 lbs.)	●
	Dry Materials	●
	Food / Pharmaceutical	●
	Vacuum Service	●
	APPLICATION REQUIREMENTS	High Flow Capacity
Low Torque		●
Fire Tested		●
Fugitive Emission Control		●
Reduced Maintenance		●
Extended Service Life		●
Size Range (inches)		½" to 24"
Pressure Rating (ANSI Classes)		150, 300
High Temperature		600°F (316°C)
Low Temperature		-40°F (-40°C)
Unique Features and Benefits		Exceptional fugitive emissions control: ISO15848-1 BH CO3 392°F (200°C) SSA 0 and API 641 Class B & E.

# How to Order

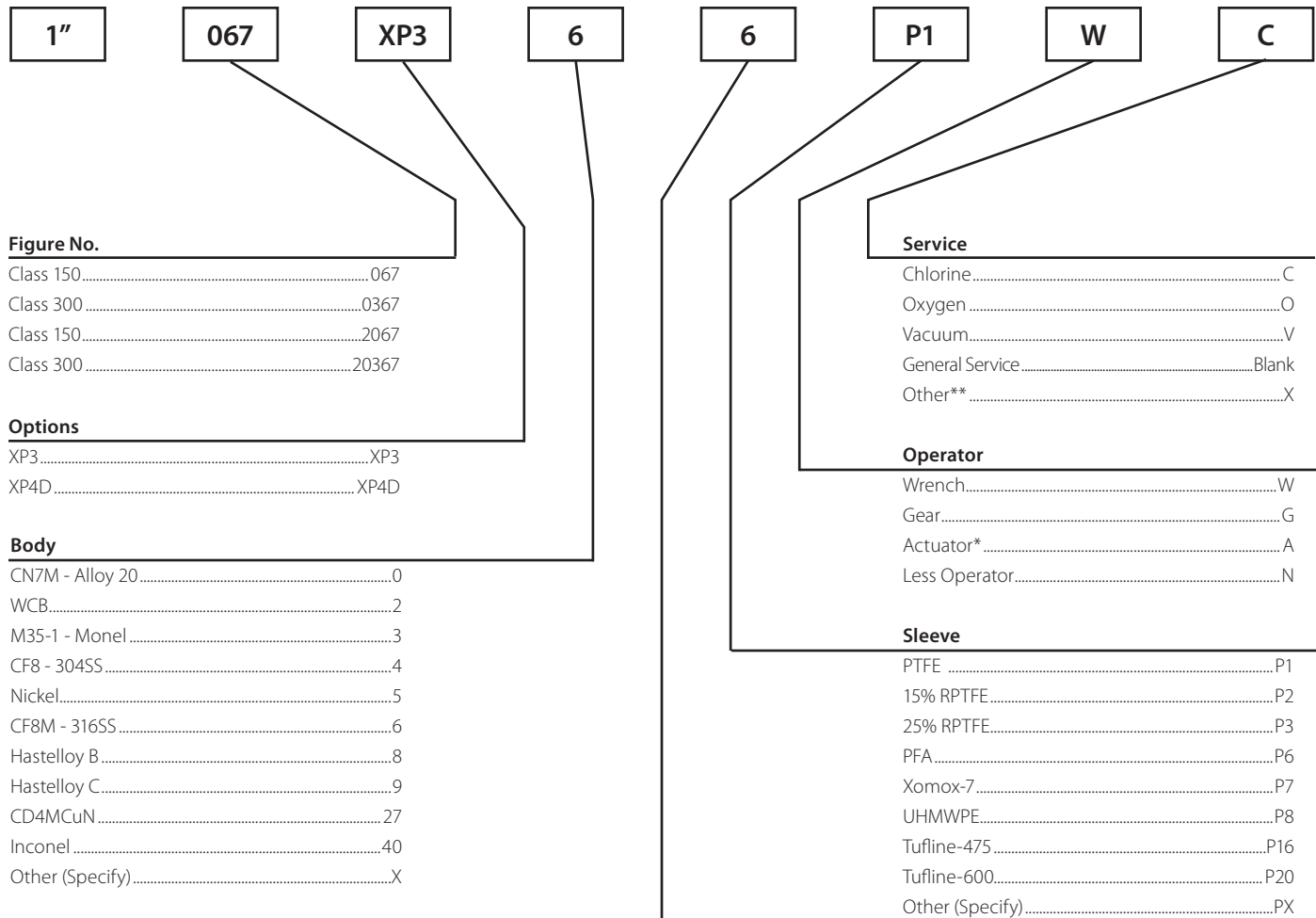

**Figure No.**

Class 150.....	067
Class 300.....	.0367
Class 150.....	.2067
Class 300.....	.20367

**Options**

XP3.....	XP3
XP4D.....	XP4D

**Body**

CN7M - Alloy 20.....	0
WCB.....	2
M35-1 - Monel.....	3
CF8 - 304SS.....	4
Nickel.....	5
CF8M - 316SS.....	6
Hastelloy B.....	8
Hastelloy C.....	9
CD4MCuN.....	27
Inconel.....	40
Other (Specify).....	X

**Service**

Chlorine.....	C
Oxygen.....	O
Vacuum.....	V
General Service.....	Blank
Other**.....	X

**Operator**

Wrench.....	W
Gear.....	G
Actuator*.....	A
Less Operator.....	N

**Sleeve**

PTFE.....	P1
15% RPTFE.....	P2
25% RPTFE.....	P3
PFA.....	P6
Xomox-7.....	P7
UHMWPE.....	P8
Tuflin-475.....	P16
Tuflin-600.....	P20
Other (Specify).....	PX

**Plug**

CN7M - Alloy 20.....	0
M35-1 - Monel.....	3
CF8 - 304SS.....	4
Nickel.....	5
CF8M - 316SS.....	6
Hastelloy B.....	8
Hastelloy C.....	9
CD4MCuN.....	27
Inconel.....	40
Other (Specify).....	X

Tuflin® automated valve packages assure single-source responsibility for flow control equipment.

With the XOMOX® family of valves, actuators, and control accessories, combined with our problem solving expertise, you are assured of valve packages that will provide optimum performance in your application.

**CRANE ChemPharma & Energy, XOMOX® Automation & Service Centers**

Our Automation & Service Centers are strategically located to provide comprehensive:

- Automated valve packing
- Valve modification
- Valve repair
- Application counseling

For more information, fast response, comprehensive service, and knowledgeable technical help, please contact your CRANE ChemPharma & Energy, XOMOX® Automation & Service Center.

\* Specify actuator type and available air supply.

\*\* Consult your Tuflin Sales Engineer for a wide variety of other available service options.





# XOMOX®

Crane ChemPharma & Energy  
XOMOX® Headquarters  
4444 Cooper Rd.  
Cincinnati, OH 45242, USA  
Tel: +1 513 745 6000  
Fax: +1 513 745 6086  
www.cranecpe.com

**CRANE**®

XOMOX® International GmbH & Co. OHG  
Von-Behring-Straße 15,  
D-88131 Lindau/Bodensee, Germany  
Tel: +49 8382 702 0  
Fax: +49 8382 702 144

## brands you trust.



Crane Co., and its subsidiaries cannot accept responsibility for possible errors in catalogues, brochures, other printed materials, and website information. Crane Co. reserves the right to alter its products without notice, including products already on order provided that such alteration can be made without changes being necessary in specifications already agreed. All trademarks in this material are property of the Crane Co. or its subsidiaries. The Crane and Crane brands logotype, in alphabetical order, (ALOYCO®, CENTER LINE®, COMPAC-NOZ®, CRANE®, DEPA®, DUO-CHEK®, ELRO®, FLOWSEAL®, JENKINS®, KROMBACH®, NOZ-CHEK®, PACIFIC VALVES®, RESISTOFLEX®, REVO®, SAUNDERS®, STOCKHAM®, UNI-CHEK®, WESTLOCK CONTROLS®, WTA®, and XOMOX®) are registered trademarks of Crane Co. All rights reserved.